



Nothing but **HEAVY DUTY.**<sup>®</sup>



# **M18 FCHS** **M18 FCHSC**

---

Original instructions



11



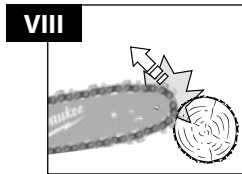
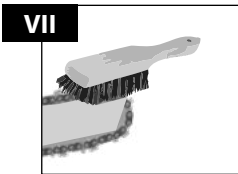
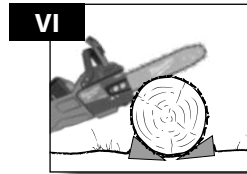
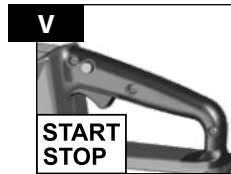
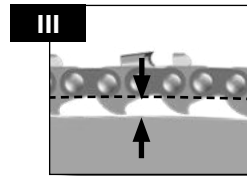
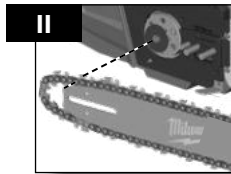

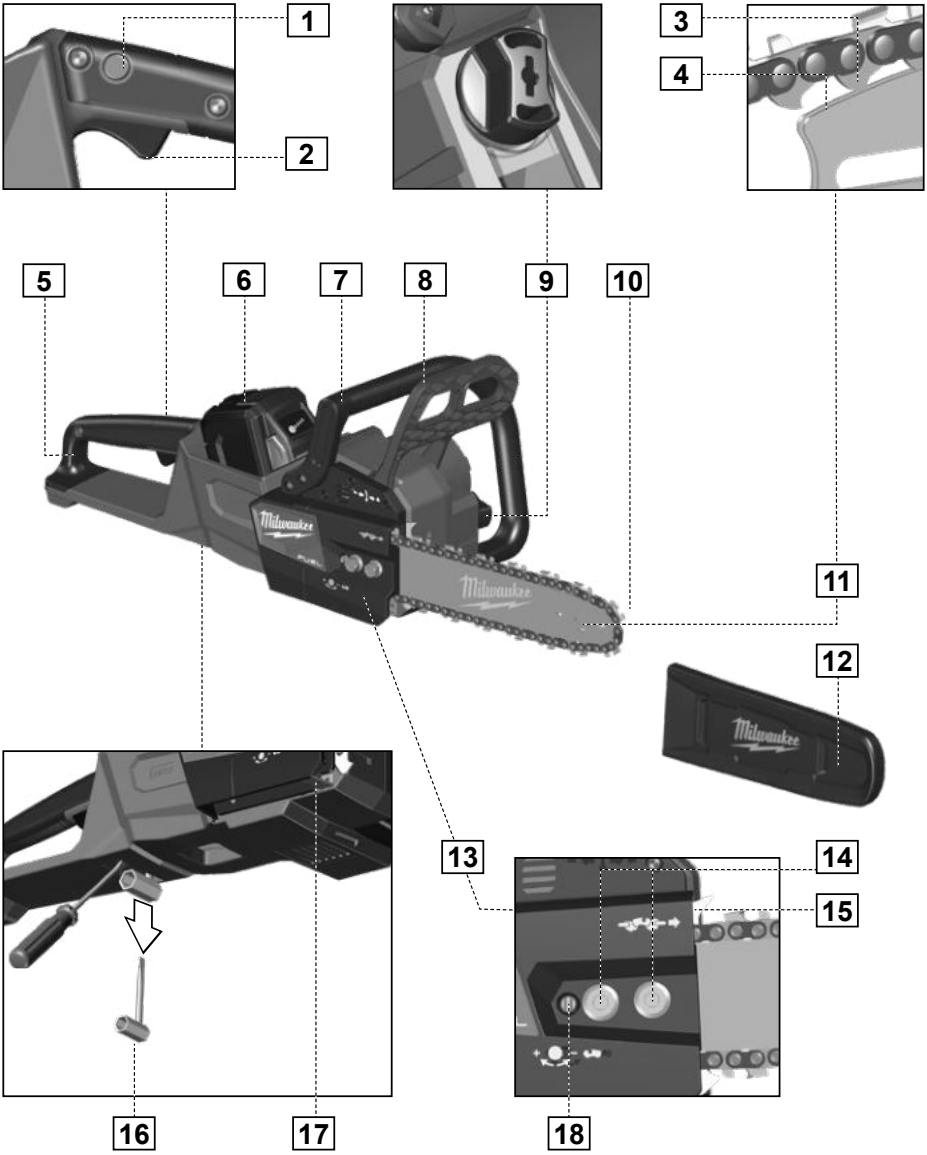

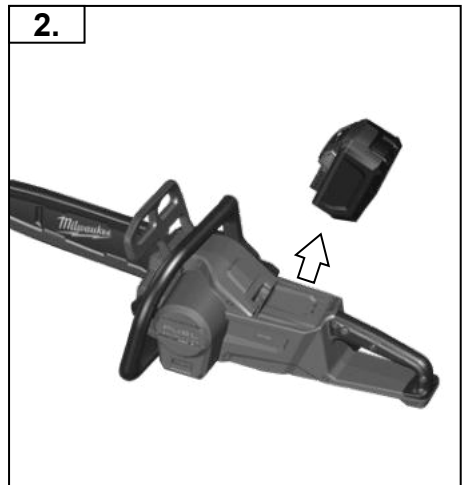
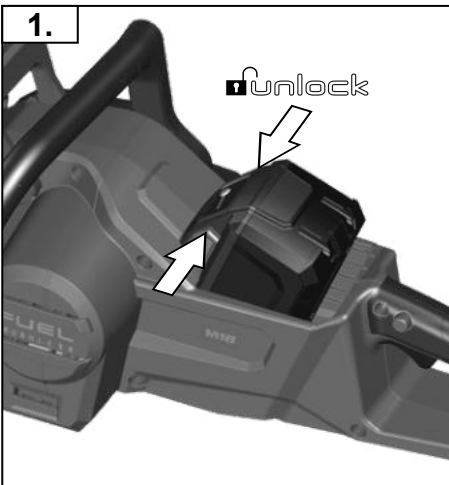
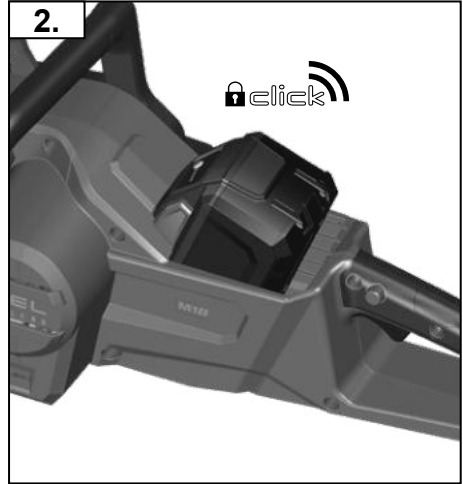
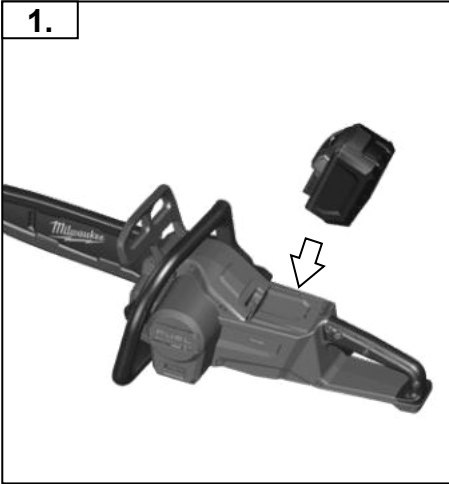

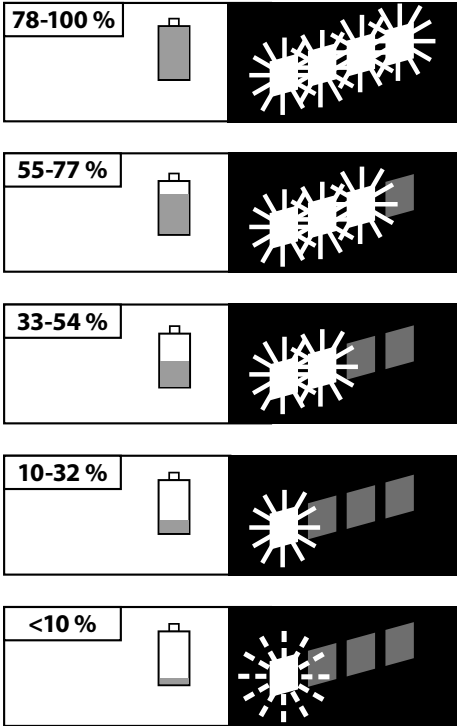

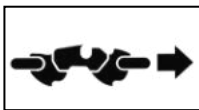
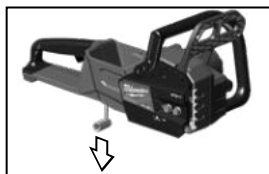
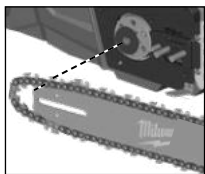

1.

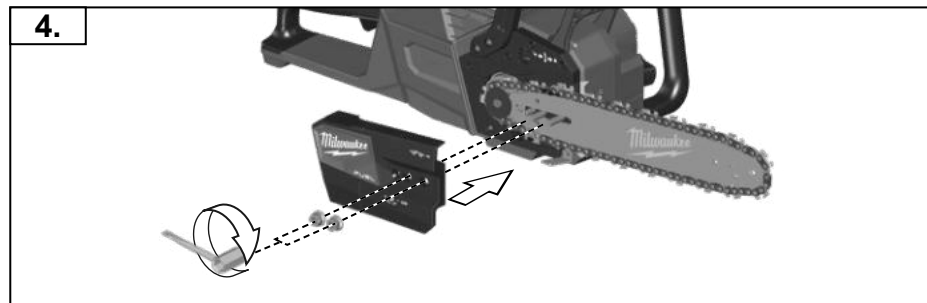
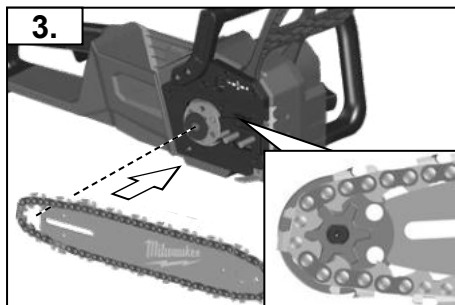
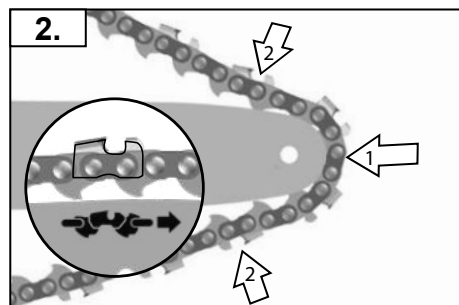
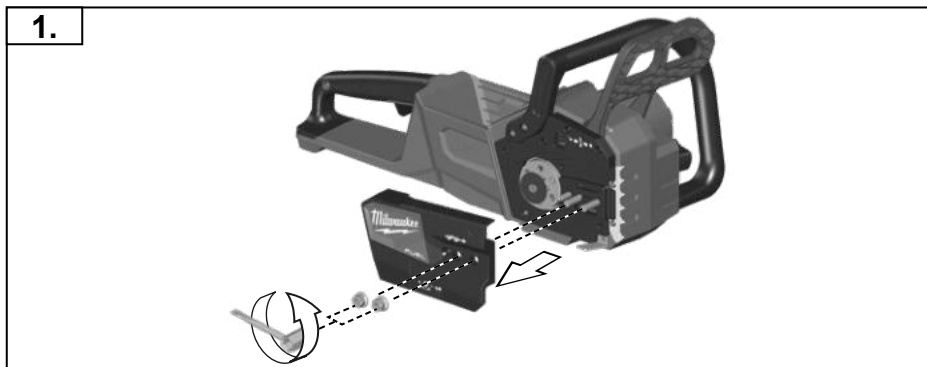

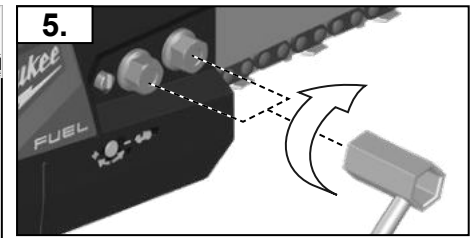
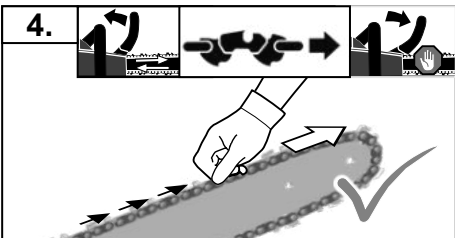
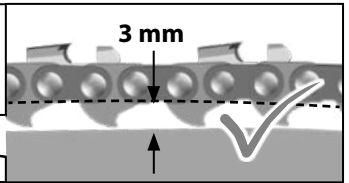
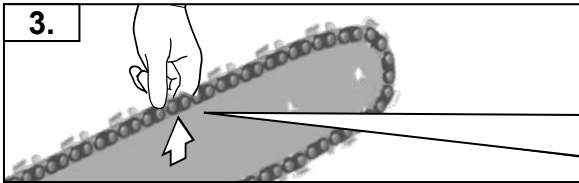
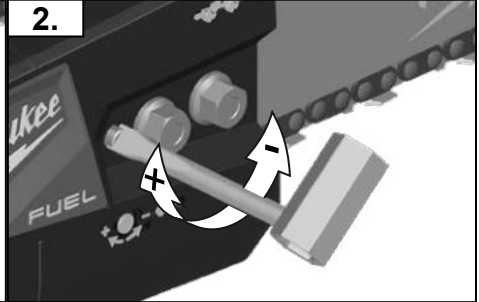
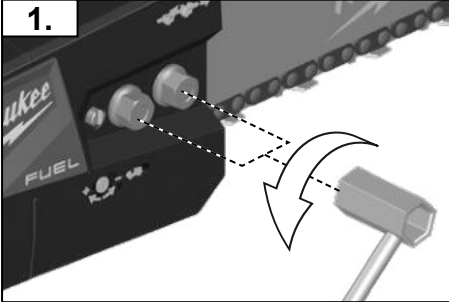
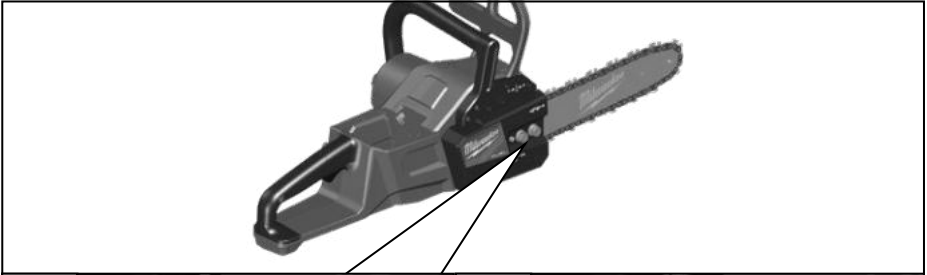
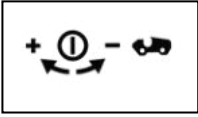
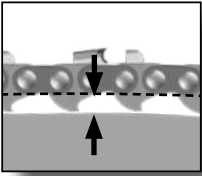



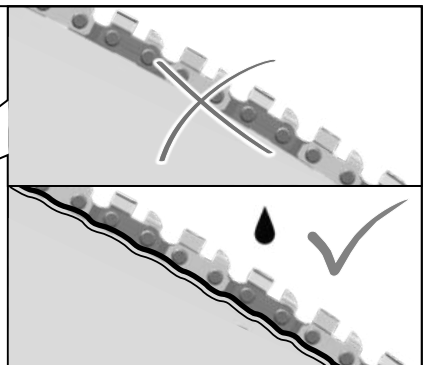
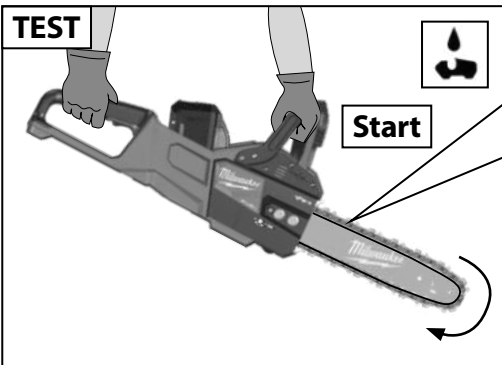
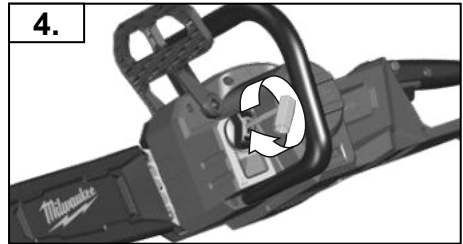
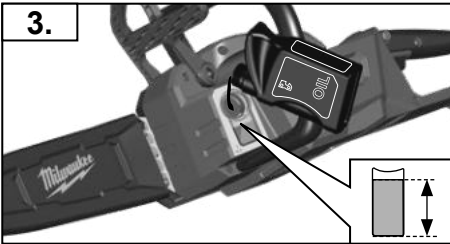
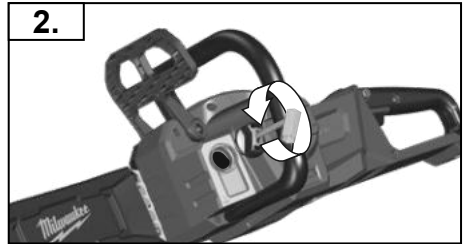

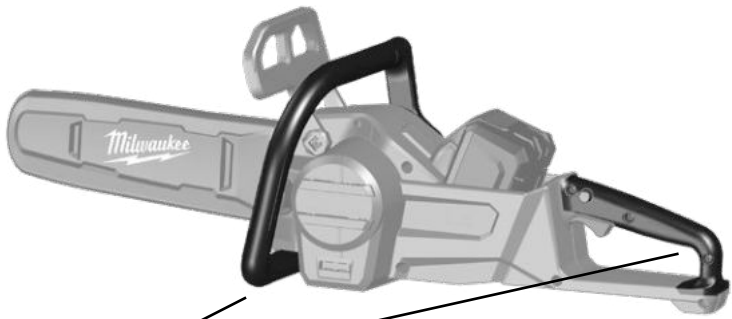
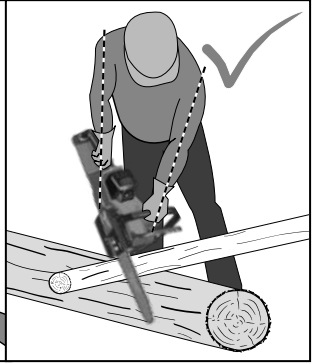
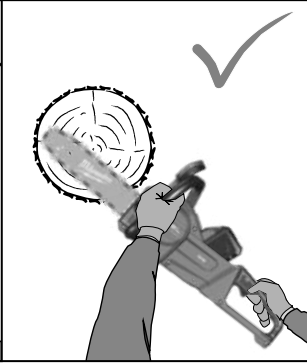
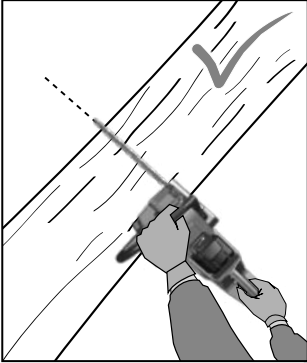

**Insulated gripping surface**



**Start**

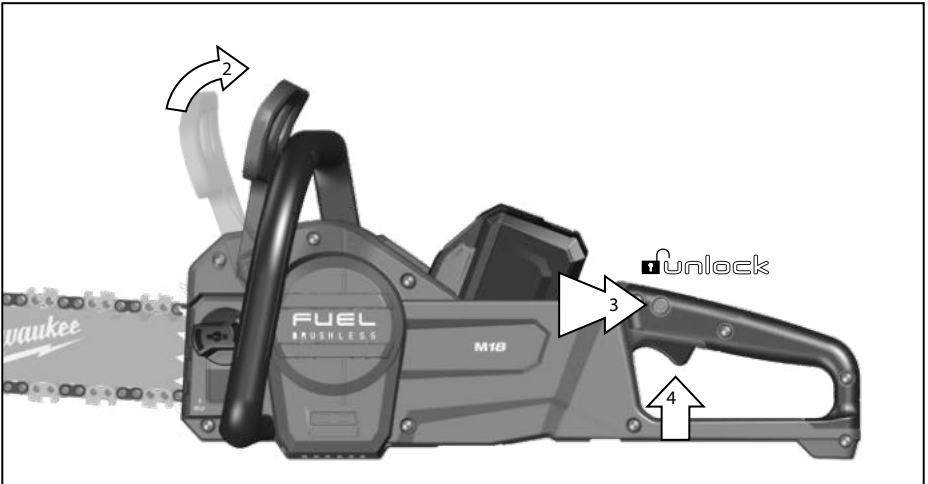
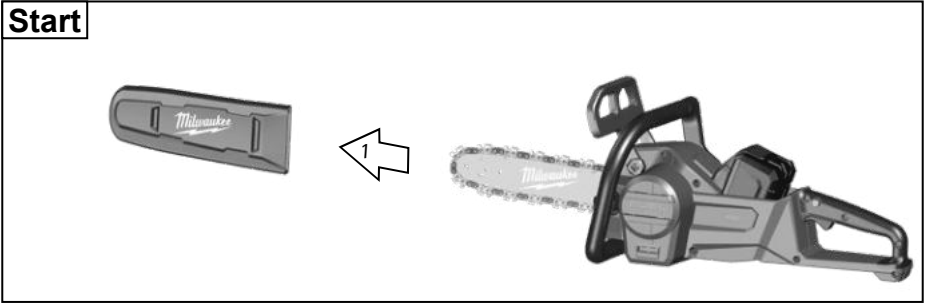

Carry out a test cut



Stop

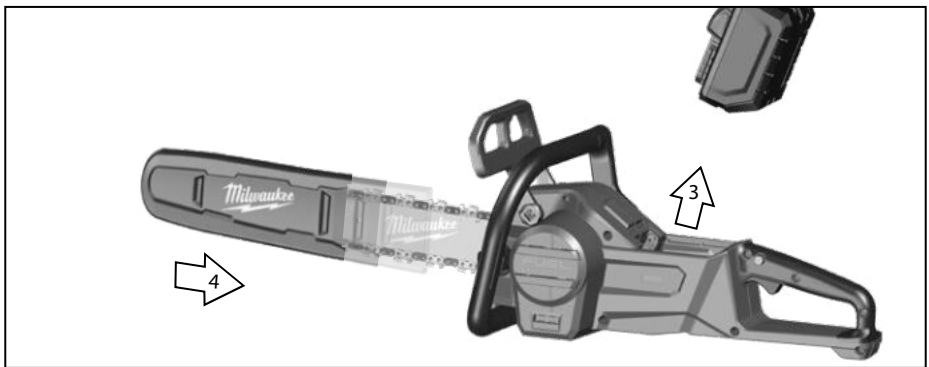

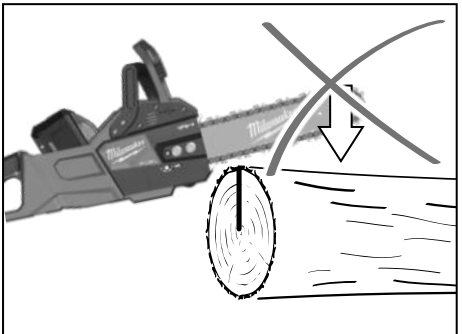
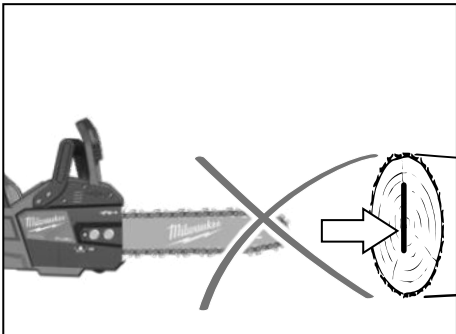
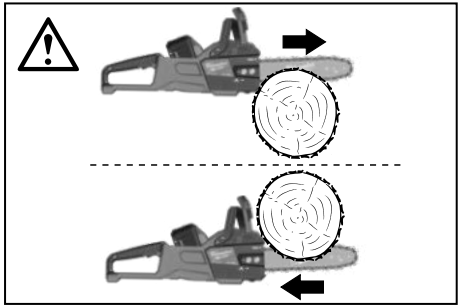
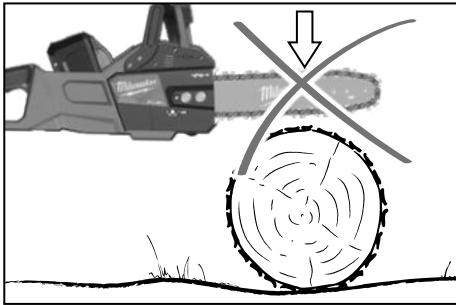
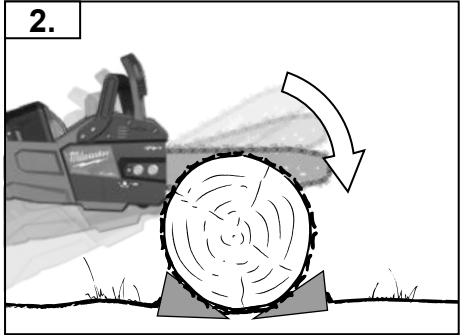
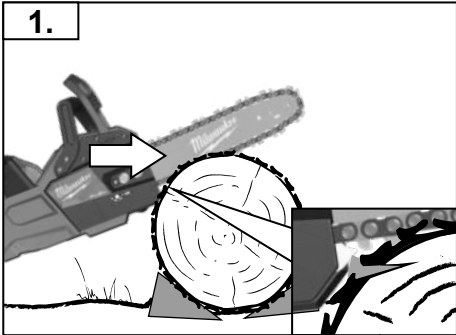
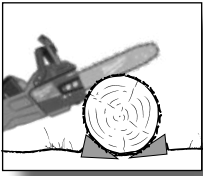

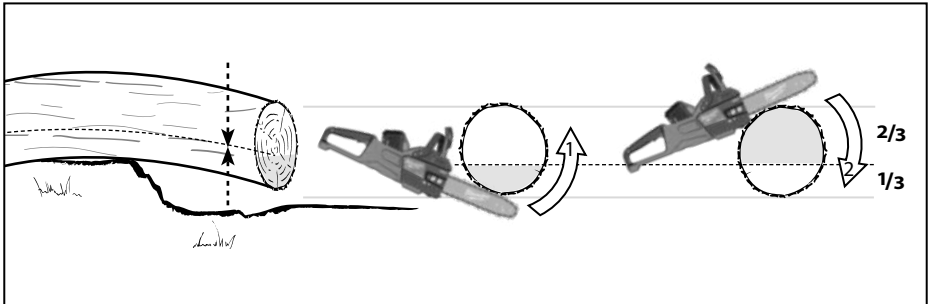
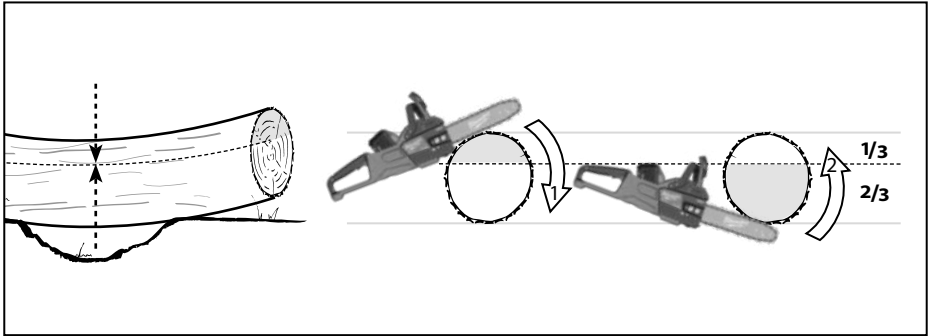
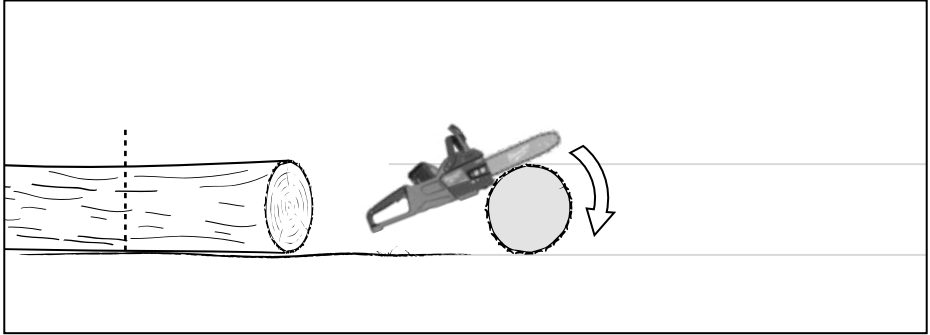
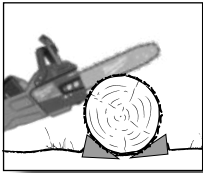

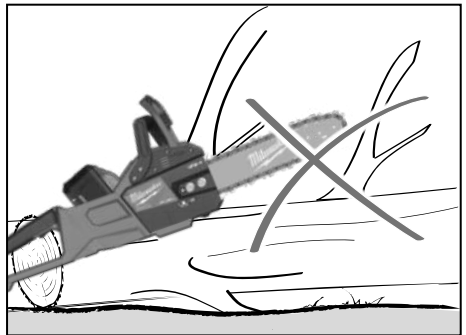
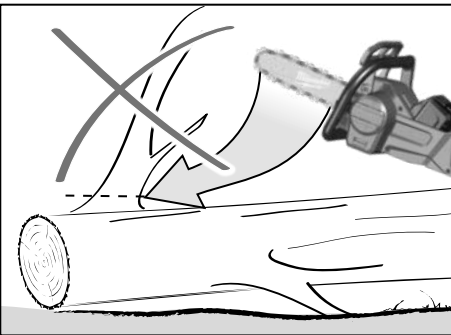
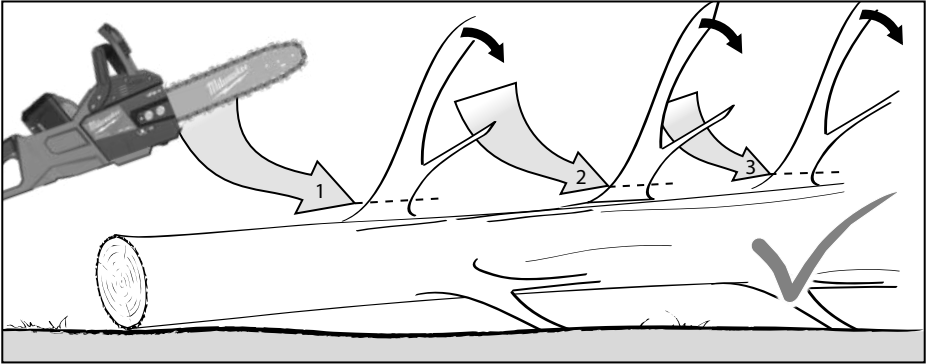
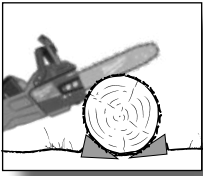

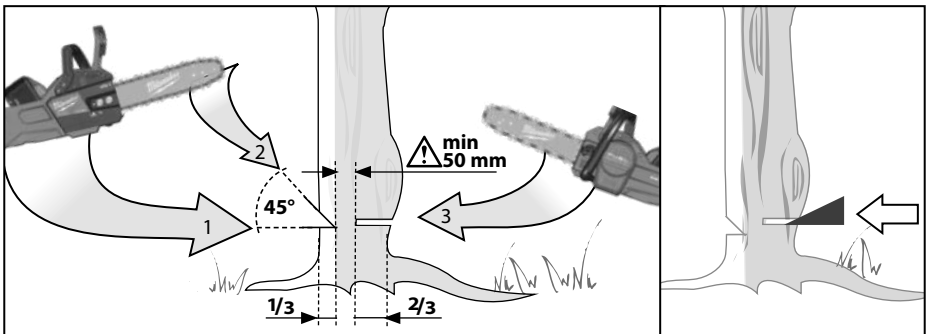
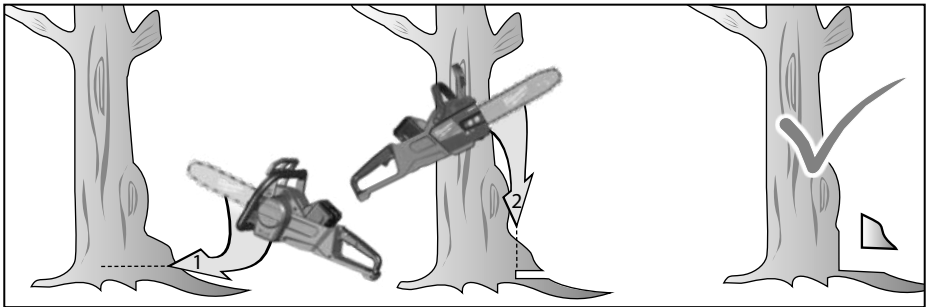
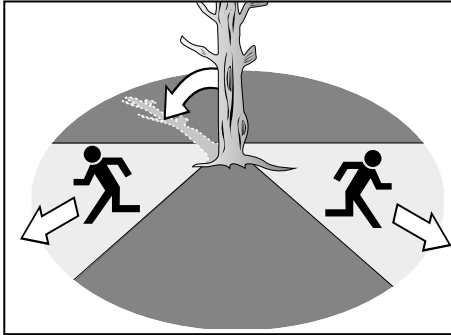
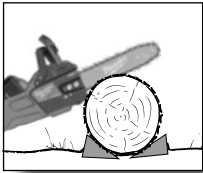



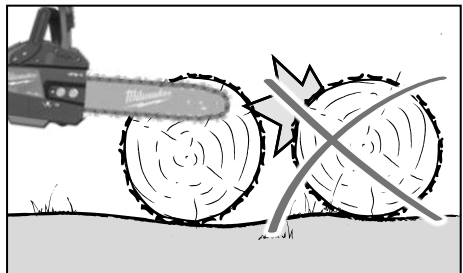
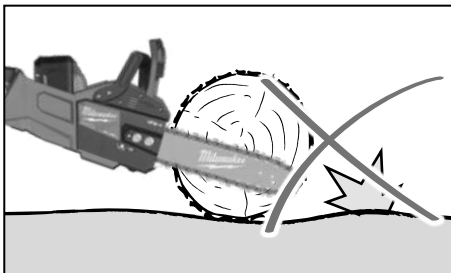
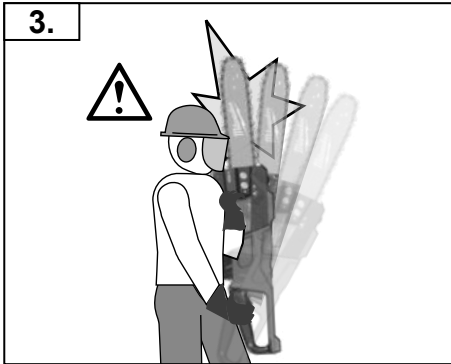
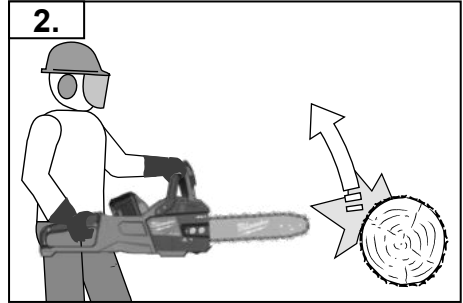
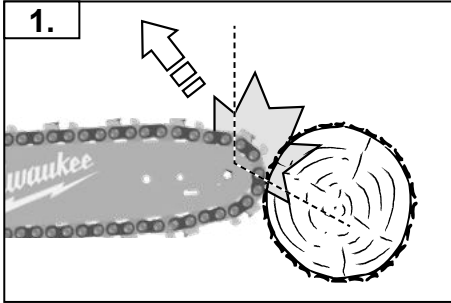
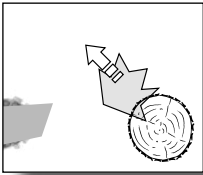

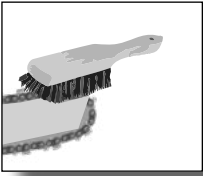

VIII

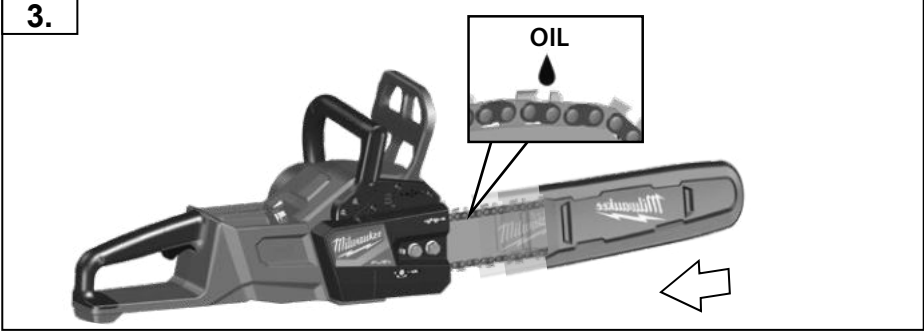
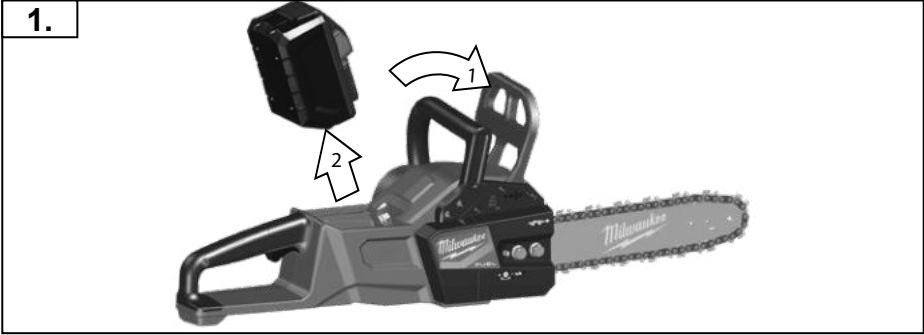

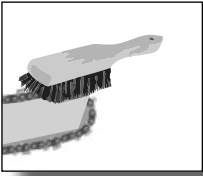

4.

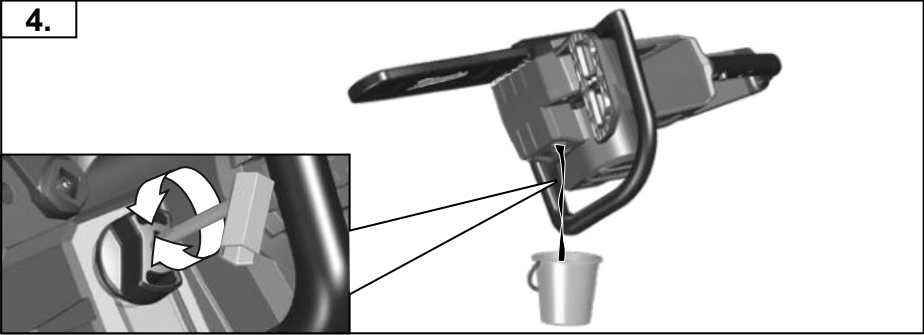

VIII

5. A



5. B

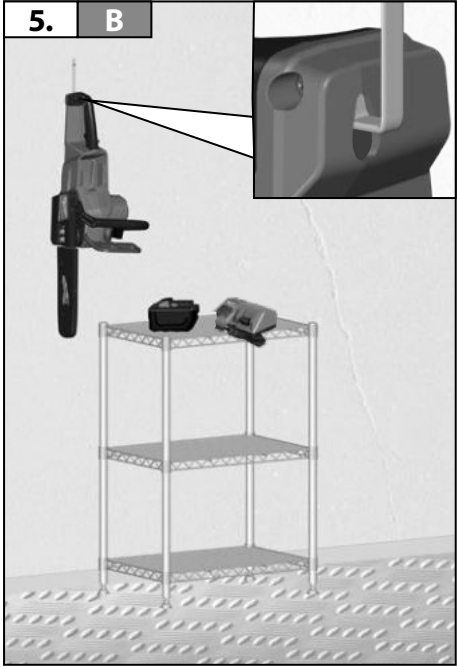

TECHNICAL DATA Chain saw	M18 FCHS	M18 FCHSC
Production code	4678 37 03 ... ... 000001-999999	4743 51 03 ... ... 000001-999999
No-load chain speed	12,4 m/s	12,4 m/s
Bar length max.	16" (406,4 mm)	12" (304,8 mm)
Usable cutting length	380 mm	280 mm
Battery voltage	18 V	18 V
Weight according EPTA-Procedure 01/2014 (Li-Ion 2,0 Ah ... 12,0 Ah)	5,3 ... 6,4 kg	5,2 ... 6,3 kg
Recommended Ambient Operating Temperature	-18°C ... +50°C	-18°C ... +50°C
Recommended battery types	M18B, M18HB12	M18B, M18HB12
Recommended charger	M12-18, M1418 C6	M12-18, M1418 C6
Chain oil tank capacity	200 ml	200 ml
<b>Noise information</b> Measured values determined according to EN 62841. Typically, the A-weighted noise levels of the tool are:		
Sound pressure level (Uncertainty K=3dB(A))	77,67 dB(A)	77,67 dB(A)
Sound power level (Uncertainty K=3dB(A))	97,69 dB(A)	97,69 dB(A)
<b>Wear ear protectors!</b>		
<b>Vibration information</b> Vibration total values (triaxial vector sum) determined according to EN 62841		
Vibration emission value $a_{hmax}$	4,96 m/s <sup>2</sup>	4,96 m/s <sup>2</sup>
Uncertainty K=	1,5 m/s <sup>2</sup>	1,5 m/s <sup>2</sup>

## WARNING

The vibration and noise emission level given in this information sheet has been measured in accordance with a standardized test given in EN 62841 and may be used to compare one tool with another. It may be used for a preliminary assessment of exposure.

The declared vibration and noise emission level represents the main applications of the tool. However if the tool is used for different applications, with different accessories or poorly maintained, the vibration and noise emission may differ. This may significantly increase the exposure level over the total working period.

An estimation of the level of exposure to vibration and noise should also take into account the times when the tool is switched off or when it is running but not actually doing the job. This may significantly reduce the exposure level over the total working period.

Identify additional safety measures to protect the operator from the effects of vibration and/or noise such as: maintain the tool and the accessories, keep the hands warm, organization of work patterns.

Wear ear protectors. Exposure to noise can cause hearing loss.



### WARNING!

**Read all safety warnings, instructions, illustrations and specifications provided with this power tool.** Failure to follow the warnings and instructions may result in electric shock, fire and/or serious injury.

**Save all warnings and instructions for future reference.**



### GENERAL CHAIN SAW SAFETY WARNINGS

**Keep all parts of the body away from the saw chain when the chain saw is operating. Before you start the chain saw, make sure the saw chain is not contacting anything.**

A moment of inattention while operating chain saws may cause entanglement of your clothing or body with the saw chain.

**Always hold the chain saw with your right hand on the rear handle and your left hand on the front handle.** Holding the chain saw with a reversed hand configuration increases the risk of personal injury and should never be done.

**Hold the chain saw by insulated gripping surfaces only, because the saw chain may contact hidden wiring.** Saw chains contacting a „live“ wire may make exposed metal parts of the chain saw „live“ and could give the operator an electric shock.

**Wear eye protection. Further protective equipment for hearing, head, hands, legs and feet is recommended.**

Adequate protective equipment will reduce personal injury from flying debris or accidental contact with the saw chain.

**Do not operate a chain saw in a tree, on a ladder, from a rooftop, or any unstable support.** Operation of a chain saw in this manner could result in serious personal injury.

**Always keep proper footing and operate the chain saw only when standing on fixed, secure and level surface.** Slippery or unstable surfaces may cause a loss of balance or control of the chain saw.

**When cutting a limb that is under tension, be alert for spring back.** When the tension in the wood fibres is released the spring loaded limb may strike the operator and /or throw the chain saw out of control.

**Use extreme caution when cutting brush and saplings.** The slender material may catch the saw chain and be whipped toward you or pull you off balance.

**Carry the chain saw by the front handle with the chain saw switched off and away from your body. When transporting or storing the chain saw, always fit the guide bar cover.** Proper handling of the chain saw will reduce the likelihood of accidental contact with the moving saw chain.

**Follow instructions for lubricating, chain tensioning and changing the bar and chain.** Improperly tensioned or lubricated chain may either break or increase the chance for kickback.

**Keep handles dry, clean, and free from oil and grease.**

Greasy, oily handles are slippery causing loss of control.

**Cut wood only. Do not use chain saw for purposes not intended. For example: do not use chain saw for cutting metal, plastic, masonry or non-wood building materials.** Use of the chain saw for operations different than intended could result in a hazardous situation.

**Do not attempt to fell a tree until you have an understanding of the risks and how to avoid them.** Serious injury could occur to the operator or bystanders while felling a tree.

**Follow all instructions when clearing jammed material, storing or servicing the chain saw. Make sure the switch is off and the battery pack is removed.** Unexpected actuation of the chain saw while clearing jammed material or servicing may result in serious personal injury.

**Causes and operator prevention of kickback:**

Kickback may occur when the nose or tip of the guide bar touches an object, or when the wood closes in and pinches the saw chain in the cut.

Tip contact in some cases may cause a sudden reverse reaction, kicking the guide bar up and back towards the operator.

Pinching the saw chain along the top of the guide bar may push the guide bar rapidly back towards the operator.

Either of these reactions may cause you to lose control of the saw which could result in serious personal injury. Do not rely exclusively upon the safety devices built into your saw.

As a chain saw user, you should take several steps to keep your cutting jobs free from accident or injury.

Kickback is the result of tool misuse and/or incorrect operating procedures or conditions and can be avoided by taking proper precautions as given below:

**Maintain a firm grip, with thumbs and fingers encircling the chain saw handles, with both hands on the saw and position your body and arm to allow you to resist kickback forces.** Kickback forces can be controlled by the operator, if proper precautions are taken. Do not let go of the chain saw.

**Do not overreach and do not cut above shoulder height.** This helps prevent unintended tip contact and enables better control of the chain saw in unexpected situations.

**Only use replacement bars and chains specified by the manufacturer.** Incorrect replacement guide bars and chains may cause chain breakage and/or kickback.

**Follow the manufacturer's sharpening and maintenance instructions for the saw chain.** Decreasing the depth gauge height can lead to increased kickback.

## Additional Safety and Working Instructions

It is recommended to cut logs on a saw-horse or cradle when operating the machine for the first time.

Ensure all guards, handles, and spiked bumper are properly fitted and are in good condition.

Persons using the chain saw should be in good health. The chain saw is heavy, so the operator must be physically fit.

The operator should be alert, have a good vision, mobility, balance, and manual dexterity. If there is any doubt, do not operate the chain saw.

Do not start using the chain saw until you have a clear work area, secure footing, and a planned retreat path away from a falling tree. Beware of the emission of lubricant mist and saw dust. Wear a mask or respirator, if required.

Do not cut vines and/or small undergrowth (less than 75 mm in diameter).

Always hold the chain saw with both hands during operation. Use a firm grip with thumbs and fingers encircling the chain saw handles. Right hand must be on the rear handle and left hand on the front handle.

Before starting the chain saw, make sure the saw chain is not contacting any object.

Do not modify the chain saw in any way or use it to power any attachments or devices not recommended by the manufacturer for your chain saw.

There should be a first-aid kit containing large wound dressings and a means to summon attention (e.g., whistle) close to the operator. A larger more comprehensive kit should be reasonably nearby.

An incorrectly tensioned chain can jump off the guide bar and could result in serious injury or fatality. The length of the chain depends on the temperature. Check the tension frequently.

You should get used to your new chain saw by making simple cuts on securely supported wood. Do this whenever you have not operated the saw for some time. To reduce the risk of injury associated with contacting moving parts, always stop the motor, apply the chain brake, remove the battery pack and make sure all moving parts have come to a stop before:

- cleaning or clearing a blockage
- leaving the machine unattended
- installing or removing attachments
- checking, conducting maintenance or working on the machine

The size of the work area depends on the job being performed as well as the size of the tree or work piece involved. For example, felling a tree requires a larger work area than making other cuts, i.e., bucking cuts, etc. The operator needs to be aware and in control of everything happening in the work area.

Do not cut with your body in line with the guide bar and chain. If you experience kickback, this will help prevent the chain coming into contact with your head or body.

Do not use a back-and-forward sawing motion, let the chain do the work. Keep the chain sharp and do not try to push the chain through the cut.

Do not put pressure on the saw at the end of the cut. Be ready to take on the weight of the saw as it cuts free from the wood. Failure to do so could result in possible serious personal injury.

Do not stop the saw in the middle of a cutting operation.

Keep the saw running until it is already removed from the cut. Do not fix the on/off switch in the „on“ position when using the saw hand-held.



Remove the battery pack before starting any work on the appliance.

**WARNING!** To reduce the risk of fire, personal injury, and product damage due to a short circuit, never immerse your tool, battery pack or charger in fluid or allow a fluid to flow inside them. Corrosive or conductive fluids, such as seawater, certain industrial chemicals, and bleach or bleach containing products, etc., can cause a short circuit.

Use only System M18 chargers for charging System M18 battery packs. Do not use battery packs from other systems.

Never break open battery packs and chargers and store only in dry rooms. Keep dry at all times.

### Push and pull

The reaction force is always opposite to the direction the chain is moving. Thus, the operator must be ready to control the tendency for the machine to pull away (forward motion) when cutting on the bottom edge of the bar and the push backwards (towards the operator) when cutting along the top edge.

### Saw jammed in the cut

Stop the chain saw and make it safe. Do not try to force the chain and bar out of the cut as this is likely to break the chain, which may swing back and strike the operator. This situation normally occurs because the wood is incorrectly supported which forces the cut to close under compression, thereby pinching the blade. If adjusting the support does not release the bar and chain, use wooden wedges or a lever to open the cut and release the saw. Never try to start the chain saw when the guide bar is already in a cut or kerf.

### Skating / Bouncing

When the chainsaw fails to dig in during a cut, the guide bar can begin hopping or dangerously skidding along the surface of the log or branch, possibly resulting in the loss of control of the chainsaw. To prevent or reduce skating or bouncing, always use the saw with both hands make sure the saw chain establishes a groove for cutting. Never cut small, flexible branches or brushes with your chainsaw. Their size and flexibility can easily cause the saw to bounce towards you or bind up with enough force to cause a kickback. The best tool for that kind of work is a hand saw, pruning shears, an axe or other hand tools.

### Personal protective equipment

Wear a helmet at all times when operating the machine. A helmet, equipped with mesh visor, can help reduce the risk of injury to the face and the head if kickback occurs. Wear ear protectors. Exposure to noise can cause hearing loss.

Good quality personal protective equipment, as used by professionals, will help reduce the risk of injury to the operator. The following items should be used when operating the machine:

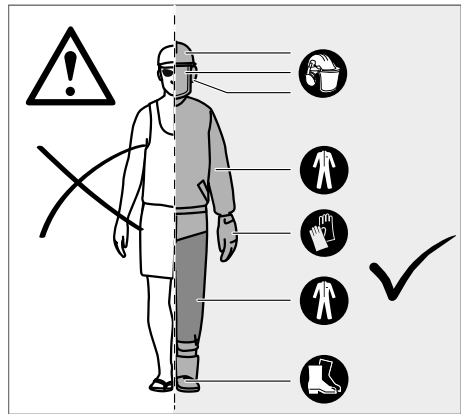

### Safety helmet

should comply with EN 397 and be CE marked

### Hearing protection

should comply with EN 352-1 and be CE marked

### Eye and face protection

should be CE marked and comply with EN 166 (for safety glasses) or EN 1731 (for mesh visors)

### Gloves

should comply with EN381-7 and be CE marked

### Leg protection (chaps)

should comply with EN 381-5, be CE marked and provide allround protection

### Chain saw safety boots

should comply with EN ISO 20345:2004 and be marked with a shield depicting a chain saw to show compliance with EN 381-3. (Occasional users may use steel toe-cap safety boots with protective gaiters which conform to EN 381-9 if the ground is even and there is little risk of tripping or catching on undergrowth)

### Chain saw jackets for upper body protection

should comply with EN 381-11 and be CE marked

## KNOW YOUR CHAIN SAW

1	Trigger Release	10	Saw Chain
2	Throttle Trigger	11	Guide Bar
3	Chain Drive	12	Guide Bar Cover
4	Bar Groove	13	Front handle / Chain Brake
5	Rear Handle	14	Bar Mounting Nuts
6	Battery	15	Spiked Bumper
7	Front handle	16	Combination Wrench
8	Front handle / Chain Brake	17	Chain Catcher
9	Chain Lubricant Cap	18	Chain Tension Screw

### WARNING!

**Consequences of improper maintenance, removal or modification of safety features like the chain brake, ignition switch, hand guard (front and back), spiked bumper, chain catcher, guide bar, low kick-back saw chain may cause the safety features to not function correctly, thus increasing the potential for serious injury.**

### Low kick-back saw chain

A low-kick-back saw chain helps to reduce the possibility of a kickback event. The rakers (depth gauges) ahead of each cutter can minimize the force of a kick-back reaction by preventing the cutters from digging in too deeply. Only use replacement guide bar and chain combinations recommended by the manufacturer. As saw chains are sharpened, they lose some of the low kickback qualities and extra caution is required. For your safety, replace saw chains when cutting performance decreases.

### Spiked Bumper

The integral bumper spike may be used as a pivot when making a cut. It helps to keep the body of the chain saw steady while cutting. When cutting, push the machine forward until the spikes dig into the edge of the wood, then by moving the rear handle up or down in the direction of the cutting line it can help ease the physical strain of cutting.

### Guide Bar

Generally, guide bars with small radius tips have somewhat lower potential for kick-back. You should use a guide bar and matching chain which is just long enough for the job. Longer bars increase the risk of loss of control during sawing. Regularly check the chain tension. When cutting smaller branches (less than the full length of the guide bar) the chain is more likely to be thrown off if the tension is not correct.

### Chain Brake

Chain brakes are designed to quickly stop the chain from rotating. When the chain brake lever/hand guard is pushed towards the bar, the chain should stop immediately. A chain brake does not prevent kickback. It only lowers the risk of injury should the chain bar contact the operator's body during a kickback event. The chain brake should be tested before each use for correct operation in both the run and brake positions.

### Chain Catcher

A chain catcher prevents the saw chain from being thrown back towards the operator if the saw chain comes loose or breaks.

## INSTRUCTIONS CONCERNING THE PROPER TECHNIQUES FOR BASIC FELLING, LIMBING AND CROSS-CUTTING

### Understanding the forces within the wood

When you understand the directional pressures and stresses inside the wood you can reduce the "pinches" or at least expect them during your cutting. Tension in the wood means the fibers are being pulled apart and if you cut in this area, the "kerf" or cut will tend to open as the saw goes through. If a log is being supported on a saw horse and the end is hanging unsupported over the end, tension is created on the upper surface due to the weight of the overhanging log stretching the fibers. Likewise, the underside of the log will be in compression and the fibers are being pushed together. If a cut is made in this area, the kerf will have the tendency to close up during the cut. This would pinch the blade.

### Felling a tree

When bucking and felling operations are being performed by two or more persons at the same time, the felling operations should be separated from the bucking operation by a distance of at least twice the height of the tree being felled.

Trees should not be felled in a manner that would endanger any person, strike any utility line, or cause any property damage.

If the tree does make contact with any utility line, the company should be notified immediately.

An escape path should be planned and cleared as necessary before cuts are started. The escape path should extend back and diagonally to the rear of the expected line of fall.

Before felling starts, consider the natural lean of the tree, the location of larger branches, and the wind direction to judge which way the tree will fall.

Remove dirt, stones, loose bark, nails, staples, and wire from the tree.

Do not attempt to fell trees which are rotten or have been damaged by wind, fire, lightning, etc. This is extremely dangerous and should only be completed by professional tree surgeons.

#### 1. Notching undercut

Make the notch 1/3 the diameter of the tree, perpendicular to the direction of the fall. Make the lower horizontal notching cut first. This will help to avoid pinching either the saw chain or the guide bar when the second notch is being made.

#### 2. Felling-back cut

Make the felling-back cut at least 50 mm/ 2 in. higher than the horizontal notching cut. Keep the felling-back cut parallel to the horizontal notching cut. Make the felling back cut so enough wood is left to act as a hinge. The hinge wood keeps the tree from twisting and falling in the wrong direction.

Do not cut through the hinge.

As the felling gets close to the hinge, the tree should begin to fall. If there is any chance that the tree may not fall in the desired direction or it may rock back and bind the saw chain, stop cutting before the felling-back cut is complete and use wedges of wood, plastic or aluminium to open the cut and drop the tree along the desired line of fall.

When the tree begins to fall remove the chain saw from the cut, stop the motor, put the chain saw down, and use the retreat path planned. Be alert for falling overhead limbs and watch your footing.



IX

## Removing buttress roots

A buttress root is a large root extending from the trunk of the tree above the ground. Remove large buttress roots prior to felling. Make the horizontal cut into the buttress first, followed by the vertical cut. Remove the resulting loose section from the work area. Follow the correct tree felling procedure after you have removed the large buttress roots.

## Limbing a tree

Limbing is removing the branches from a fallen tree. When limbing, leave larger lower limbs to support the log off the ground. Remove the small limbs in one cut. Branches under tension should be cut from the bottom up to avoid binding the chain saw.

## Bucking a log

Bucking is cutting a log into lengths. It is important to make sure your footing is firm and your weight is evenly distributed on both feet. When possible, the log should be raised and supported by the use of limbs, logs or chocks.

Follow the simple directions for easy cutting. When the log is supported along its entire length, it is cut from the top (overbuck).

When the log is supported on one end, cut 1/3 the diameter from the underside (underbuck). Then make the finished cut by overbucking to meet the first cut.

When the log is supported on both ends, cut 1/3 the diameter from the top (overbuck). Then make the finished cut by underbucking the lower 2/3 to meet the first cut.

When bucking on a slope always stand on the uphill side of the log. To maintain control when "cutting through", release the cutting pressure near the end of the cut without relaxing your grip on the chain saw handles. Don't let the chain contact the ground. After completing the cut, wait for the saw chain to stop before you move the chain saw. Always stop the motor before moving from tree to tree.

## Cutting springpoles

A springpole is any log, branch, rooted stump, or sapling which is bent under tension by other wood so that it springs back if the wood holding it is cut or removed.

On a fallen tree, a rooted stump has a high potential of springing back to the upright position during the bucking cut to separate the log from the stump. Watch out for springpoles—they are dangerous.

**WARNING! Springpoles are dangerous and could strike the operator, causing the operator to lose control of the chain saw. This could result in severe or fatal injury to the operator. This should be done by trained users.**

### ADDITIONAL SAFETY WARNINGS

Some regions have regulations that restrict the use of the machine. Check with your local authority for advice.

Never allow children or people unfamiliar with the instructions to use the machine. Local regulations may restrict the age of the operator.

Ensure before each use that all controls and safety devices function correctly. Do not use the machine if the "off" switch does not stop the motor.

Do not wear loose fitting clothing, short trousers, or jewellery of any kind.

Secure long hair so it is above shoulder level to prevent entanglement in moving parts.

Beware of thrown, flying, or falling objects. Keep all bystanders, children, and animals at least 15 m away from the work area.

Do not operate in poor lighting. The operator requires a clear view of the work area to identify potential hazards.

Use of hearing protection reduces the ability to hear warnings (shouts or alarms). The operator must pay extra attention to what is going on in the work area.

Operating similar tools nearby increases both the risk of hearing injury and the potential for other persons to enter your work area.

Keep firm footing and balance. Do not overreach.

Overreaching can result in loss of balance and can increase the risk of kickback.

Keep all parts of your body away from any moving part.

Inspect the chain saw before each use. Check for correct operation of all controls, including the chain brake. Check for loose fasteners, make sure all guards and handles are properly and securely attached. Replace any damaged parts before use.

Do not modify the machine in any way or use parts and accessories which are not recommended by the manufacturer.

**WARNING! If the machine is dropped, suffers heavy impact or begins to vibrate abnormally, immediately stop the machine and inspect for damage or identify the cause of the vibration. Any damage should be properly repaired or replaced by an MILWAUKEE service station.**

Do not dispose of used battery packs in the household refuse or by burning them. Milwaukee Distributors offer to retrieve old batteries to protect our environment. Do not store the battery pack together with metal objects (short circuit risk).

Use only System M18 chargers for charging System M18 battery packs. Do not use battery packs from other systems.

Battery acid may leak from damaged batteries under extreme load or extreme temperatures. In case of contact with battery acid wash it off immediately with soap and water. In case of eye contact rinse thoroughly for at least 10 minutes and immediately seek medical attention.

### RESIDUAL RISK

Even when the product is used as prescribed, it is still impossible to completely eliminate certain residual risk factors. The following hazards may arise in use and the operator should pay special attention to avoid the following:

- Injury caused by vibration  
Always use the right tool for the job. Use designated handles. Restrict working time and exposure.
- Damage to hearing due to exposure to noise  
Wear hearing protection and limit exposure.
- Injury caused by contact with exposed saw teeth of the chain
- Injury caused by thrown-out pieces of the workpiece (wood chips, splinters)
- Injury caused by dust and particles
- Injury to the skin caused by contact with lubricants
- Parts ejected from the saw chain (cutting/injection hazards)
- Unforeseen, abrupt movement, or kickback of the guide bar (cutting hazards)\*





## RISK REDUCTION

- It has been reported that vibrations from handheld tools may contribute to a condition called Raynaud's Syndrome in certain individuals. Symptoms may include tingling, numbness, and blanching of the fingers, usually apparent upon exposure to cold. Hereditary factors, exposure to cold and dampness, diet, smoking and work practices are all thought to contribute to the development of these symptoms. There are measures that can be taken by the operator to possibly reduce the effects of vibration:
- Keep your body warm in cold weather. When operating the unit wear gloves to keep the hands and wrists warm.
- After each period of operation, exercise to increase blood circulation.
- Take frequent work breaks. Limit the amount of exposure per day.
- Protective gloves available from professional chain saw retailers are designed specifically for chain saw use which give protection, good grip and also reduce the effect of handle vibration. These gloves should comply with EN 381-7 and must be CE marked.

If you experience any of the symptoms of this condition, immediately discontinue use and see your doctor.

 **WARNING!** Injuries may be caused, or aggravated, by prolonged use of a tool. When using any tool for prolonged periods, ensure you take regular breaks.

## SPECIFIED CONDITIONS OF USE

The cordless chain saw is only intended for use outdoors.

For safety reasons, the chain saw must be adequately controlled by using two-handed operation at all times.

The chain saw is designed for cutting branches, trunks, logs, and beams of a diameter determined by the cutting length of the guide bar. It is only designed to cut wood. It is only to be used by adults who have received adequate training on the hazards and preventative measures/actions to be taken while using the chain saw.

Do not use the chain saw for any purpose not listed in the specified conditions of use. It is not to be used for professional tree services. The chain saw is not to be used by children or by persons not wearing adequate personal protective equipment and clothing.

**WARNING! When using the chain saw, the safety rules must be followed. For your own safety and that of bystanders, you must read and fully understand these instructions before operating the chain saw. You should attend a professionally organized safety course in the use, preventative actions, first-aid, and maintenance of chain saws. Please keep these instructions safe for later use.**

**WARNING! Chain saws are potentially dangerous tools. Accidents involving the use of chain saws often result in loss of limbs or death. It is not just the chain saw that is the hazard. Falling branches, toppling trees, and rolling logs can all kill. Diseased or rotting timber poses additional hazards. You should assess your capability of completing the task safely. If there is any doubt, leave it to a professional tree surgeon.**

Do not use this product in any other way as stated for normal use.

## ASSEMBLY

### Assembling saw chain and guide bar

 **WARNING! If any parts are damaged or missing do not operate the machine until the parts are replaced. Failure to heed this warning could result in serious personal injury.**

Make sure to remove the battery. Wear gloves!

1. Remove the bar mounting nuts using the combination wrench provided.
2. Remove the chain cover.
3. Put the chain in the correct direction onto the bar and make sure that the drive links are aligned in the bar groove.
4. Attach the bar to the chain saw and loop the chain around the drive sprocket.
5. Replace the chain cover and bar mounting nuts.
6. Finger-tighten the bar mounting nuts. The bar must be free to move for chain tension adjustment.
7. Adjust the chain tension. Refer to the "Adjusting chain tension" section.
8. Hold the tip of the guide bar up and tighten the bar mounting nuts securely.

 **WARNING! The saw chain is sharp. Always wear protective gloves when performing maintenance to the chain.**

### Adjusting the chain tension

Remove the battery pack before you do any work on the chain saw.

To increase the chain tension, turn the chain tensioning screw clockwise and check the chain tension frequently. To reduce the chain tension, turn the chain tensioning screw counterclockwise and check the chain tension frequently.

The chain tension is correct when the gap between the cutter in the chain and the bar is about 6,8 mm. Pull the chain in the middle of the lower side of the bar downwards (away from the bar) and measure the distance between the bar and the chain cutters. Tighten the bar mounting nuts by turning it counter clockwise.

Note Do not over-tension the chain - excess tension will cause excessive wear and will reduce the life of the chain and could damage the bar. New chains could stretch and loosen during initial use. Remove battery pack and check chain tension frequently during the first two hours of use. The temperature of the chain increases during normal operation causing the chain to stretch. Check the chain tension frequently and adjust as required. A chain tensioned while warm may be too tight upon cooling. Make sure that the chain tension is correctly adjusted as specified in these instructions.

## OPERATION

### Adding the chain lubricating oil

**WARNING! Never work without chain lubricant. If the saw chain is running without lubricant, the guide bar and the saw chain can be damaged. It is essential to frequently check the oil level in the oil level gauge and before starting to use the chain saw.**

Keep the reservoir more than  $\frac{1}{4}$  full to ensure sufficient oil is available for the job.



Note It is recommended to use a vegetable based chain oil when pruning trees. Mineral oil may harm trees. Never use waste oil automotive oil, or very thick oils. These could damage the chain saw. Clear surface around the oil cap to prevent contamination.

1. Unscrew and remove the cap from the oil tank.
2. Pour the oil into the oil tank and monitor the oil level gauge.
3. Put the oil cap back on and tighten it up. Wipe away any spillage.

### Holding the chain saw

Always hold the chain saw with your right hand on the rear handle and your left hand on the front handle. Grip both handles with the thumbs and fingers encircling the handles.

### Starting the chain saw

Before starting the chain saw, you should install the battery pack in the chain saw and make sure the chain brake is in run position by pulling the chain brake lever/hand guard toward the front handle.

Starting the chain saw

### Checking and operating the chain brake

Engage the chain brake by rotating your left hand around the front handle. Allow the back of your hand to push the chain brake lever/hand guard toward the bar while the chain is rotating rapidly. Be sure to maintain both hands on the saw handles at all times.

Reset the chain brake back into the run position by grasping the top of the chain brake lever/hand guard and pulling toward the front handle until you hear a click.

**WARNING! If the chain brake does not stop the chain immediately, or if the chain brake will not stay in the run position without assistance, bring the chain saw to an MILWAUKEE service station for repair prior to use.**

## TRANSPORTATION AND STORAGE

Always lightly oil the chain when storing to prevent rust. Always empty the oil tank when storing to prevent leakage.

Stop the machine, remove the battery, and allow it to cool before storing or transporting.

Clean all foreign materials from the machine. Store the machine in a cool, dry, and well-ventilated place that is inaccessible to children. Keep away from corrosive agents, such as garden chemicals and de-icing salts. Do not store outdoors.

Fit the guide bar cover before storing the machine or during transportation.

For transportation in vehicles, secure the machine against movement or falling to prevent injury to persons or damage to the machine.

## MAINTENANCE

**WARNING! Use only Milwaukee accessories and Milwaukee spare parts.** Failure to do so can cause possible injury, contribute to poor performance, and may void your warranty.

Use only Milwaukee accessories and Milwaukee spare parts. Should components need to be replaced which have not been described, please contact one of our Milwaukee service agents (see our list of guarantee/service addresses).

**WARNING!** Servicing requires extreme care and knowledge and should be performed only by a qualified service technician. For service, we suggest you bring the machine to your nearest MILWAUKEE service station for repair. When servicing, use only identical replacement parts. **WARNING!** Remove the battery before adjustment, maintenance or cleaning. Failure to do so could result in serious personal injury. You may only make adjustments or repairs described in this manual. For other repairs, contact the authorised service agent.

Consequences of improper maintenance may cause the chain brake and other safety features to not function correctly, thus increasing the potential for serious injury.

Keep your chain saw professionally maintained and safe. Sharpening the chain safely is a skilled task. Therefore, the manufacturer strongly recommends that a worn or dull chain is replaced with a new one, available at your MILWAUKEE service agent. The part number is available in the product specification table in this manual.

Follow instructions for lubricating and chain tension checking and adjustment.

After each use, clean the machine with a soft dry cloth.

Remove any chips, dirt and debris in the battery bay.

Check all nuts, bolts, and screws at frequent intervals for security to ensure the machine is in safe working condition. Any part that is damaged should be properly repaired or replaced by an MILWAUKEE service station.

### Replacing the guide bar and saw chain

Wear protective gloves.

1. Remove the bar mounting nuts using the combination wrench provided.
2. Remove the chain cover.
3. Put the chain in the correct direction onto the bar and make sure that the drive links are aligned in the bar groove.
4. Attach the bar to the chain saw and loop the chain around the drive sprocket.
5. Replace the chain cover and bar mounting nuts.
6. Finger-tighten the bar mounting nuts. The bar must be free to move for chain tension adjustment.
7. Adjust the chain tension. Refer to the "Adjusting chain tension" section.
8. Hold the tip of the guide bar up and tighten the bar mounting nuts securely.

**WARNING! A dull or improperly sharpened chain can cause excessive motor speed during cutting which may result in severe motor damage.**

**WARNING! Improper chain sharpening increases the potential of kickback.**

**WARNING! Failure to replace or repair a damaged chain can cause serious injury.**

**WARNING! The saw chain is sharp. Always wear protective gloves when performing maintenance to the chain.**

### Inspecting and cleaning the chain brake

Always keep the chain brake mechanism clean by lightly brushing the linkage free from dirt.

Always test the chain brake performance after cleaning.

Refer to "Checking and operating the chain brake" section in this manual for additional information.

## Maintenance schedule

### Daily check

Bar lubrication	Before each use
Chain tension	Before each use and frequently
Chain sharpness	Before each use, visual check
For damaged parts	Before each use
For loose fasteners	Before each use
Chain brake function	Before each use/inspect and clean
Guide Bar	Before each use
Complete saw	After each use
Chain Brake	Every 5 hours of operation

## Replacement parts (Bar and chain)

Manufacturer	MILWAUKEE	OREGON
Chain	4932464873	90PX056G
Guide Bar	4931469379	MLEA041

Chain must be fitted with bar from the same manufacturer according to above combinations.

## Exploded view

If needed, an exploded view of the tool can be ordered. Please state the Article No. as well as the machine type printed on the label and order the drawing at your local service agents or directly at: Techtronic Industries GmbH, Max-Eyth-Straße 10, 71364 Winnenden, Germany.

## BATTERIES

Battery packs which have not been used for some time should be recharged before use.

Temperatures in excess of 50°C (122°F) reduce the performance of the battery pack. Avoid extended exposure to heat or sunshine (risk of overheating).

The contacts of chargers and battery packs must be kept clean.

For an optimum life-time, the battery packs have to be fully charged, after use.

To obtain the longest possible battery life remove the battery pack from the charger once it is fully charged.

For battery pack storage longer than 30 days: Store the battery pack where the temperature is below 27°C and away from moisture. Store the battery packs in a 30% - 50% charged condition. Every six months of storage, charge the pack as normal.

No metal parts must be allowed to enter the battery section of the charger (short circuit risk).

## BATTERY PACK PROTECTION

In extremely high torque, binding, stalling and short circuit situations that cause high current draw, the tool will stop for about 2 seconds and then the tool will turn OFF.

## TRANSPORTING LITHIUM BATTERIES

Lithium-ion batteries are subject to the Dangerous Goods Legislation requirements.

Transportation of those batteries has to be done in accordance with local, national and international provisions and regulations.

The user can transport the batteries by road without further requirements.

Commercial transport of Lithium-Ion batteries by third parties is subject to Dangerous Goods regulations. Transport preparation and transport are exclusively to be carried out by appropriately trained persons and the process has to be accompanied by corresponding experts.

When transporting batteries:

Ensure that battery contact terminals are protected and insulated to prevent short circuit. Ensure that battery pack is secured against movement within packaging. Do not transport batteries that are cracked or leak. Check with forwarding company for further advice

## EC-DECLARATION OF CONFORMITY

We declare under our sole responsibility that the product described under "Technical Data" fulfills all the relevant provisions of the directives

2011/65/EU (RoHS)

2006/42/EC

2014/30/EU

and the following harmonized standards have been used.

EN 62841-1:2015

EN 62841-4-1:2020

EN 55014-1:2017+A11:2020

EN 55014-2:2015

EN IEC 63000:2018

Measured sound power level: 97,69 dB(A)

Guaranteed sound power level: 100 dB(A)

Conformity assessment procedure according 2000/14/EC amended by 2005/88/EC to Annex V.



Winnenden, 2021-08-02

Alexander Krug / Managing Director  
Authorized to compile the technical file

Techtronic Industries GmbH  
Max-Eyth-Straße 10, 71364 Winnenden, Germany



IX

## GB-DECLARATION OF CONFORMITY

We declare as the manufacturer under our sole responsibility that the product described under „Technical Data“ fulfills all the relevant provisions of the following Regulations  
S.I. 2012/3032 (as amended), S.I. 2008/1597 (as amended),  
S.I. 2016/1091 (as amended) and that the following designated standards have been used:

BS EN 62841-1:2015  
BS EN 62841-4-1:2020  
BS EN 55014-1:2017+A11:2020  
BS EN 55014-2:2015  
BS EN IEC 63000:2018

Measured sound power level: 97,69 dB(A)  
Guaranteed sound power level: 100 dB(A)

Conformity assessment procedure according 2000/14/EC amended by 2005/88/EC to Annex V.

Winnenden, 2021-08-02



Alexander Krug / Managing Director  
Authorized to compile the technical file

Technronic Industries GmbH  
Max-Eyth-Strasse 10, 71364 Winnenden, Germany

## SYMBOLS



CAUTION! WARNING! DANGER!



Remove the battery pack before starting any work on the appliance.



Please read the instructions carefully before starting the machine.



Wear a protective helmet.



Wear ear protectors!  
Use safety glasses.



Always wear protective clothing and footwear.



Wear safety shoes with cut protection, grippy sole and steel toe!



Wear gloves!



Never expose tool to rain.



Beware of chain saw kickback and avoid contact with bar tip



Not use one-handed



Always use chain saw two-handed



Set the chain brake to the RUN position.



Set the chain brake to the BRAKE position.



Rotate to adjust chain tension



Chain running direction

V

Voltage



Direct Current

V<sub>0</sub>

No-load chain speed



Guaranteed sound power level 100 dB(A)



Do not dispose electric tools, batteries/rechargeable batteries together with household waste material. Electric tools and batteries that have reached the end of their life must be collected separately and returned to an environmentally compatible recycling facility. Check with your local authority or retailer for recycling advice and collection point.



European Conformity Mark



British Conformity Mark



Ukraine Conformity Mark



EurAsian Conformity Mark

Copyright 2021  
Techtronic Industries GmbH  
Max-Eyth-Straße 10  
71364 Winnenden  
Germany  
+49 (0) 7195-12-0  
[www.milwaukeeetool.eu](http://www.milwaukeeetool.eu)

Techtronic Industries (UK) Ltd  
Fieldhouse Lane  
Marlow Bucks SL7 1HZ  
UK



**EAC UK  
CA**

(08.21)

**4100 4252 71**