

Milwaukee[®]

Nothing but **HEAVY DUTY**.[®]



AG 1000-125 EK
AG 1000-125 EKV

Original instructions

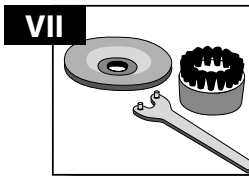
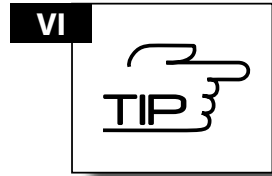
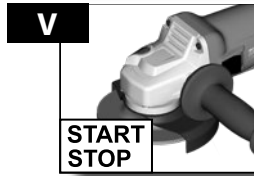
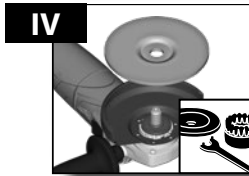
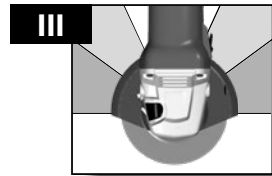
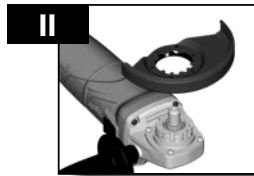
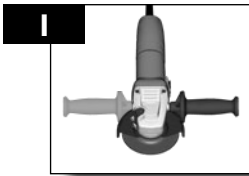

VIII Technical Data, Safety Instructions, Specified Conditions of Use, Declaration of Conformity, Batteries, Maintenance, Symbols
Please read and save these instructions!



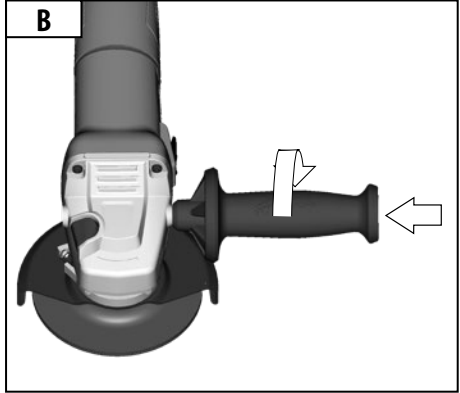
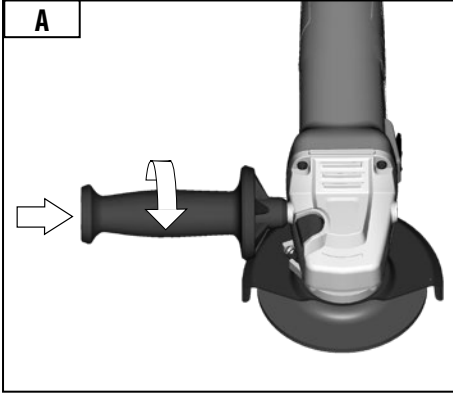
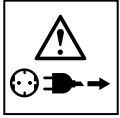
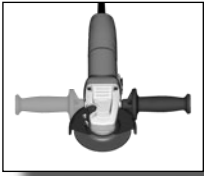

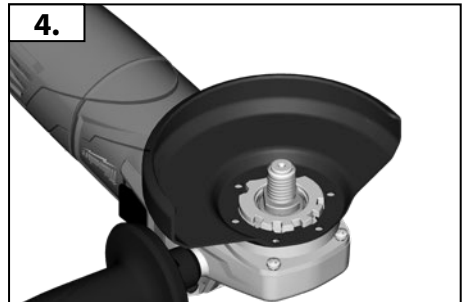
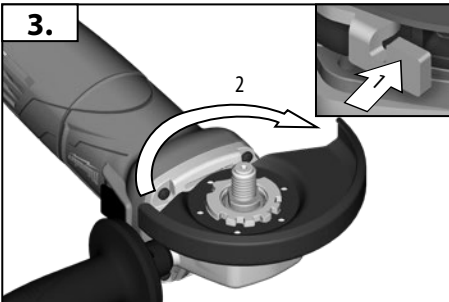
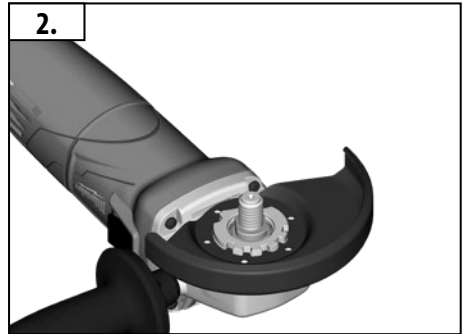
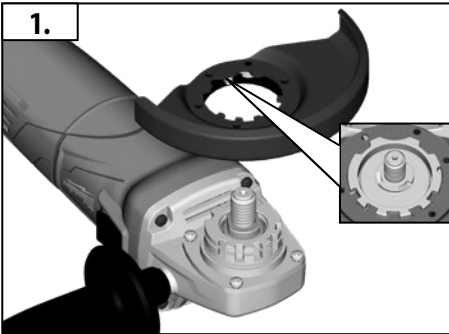
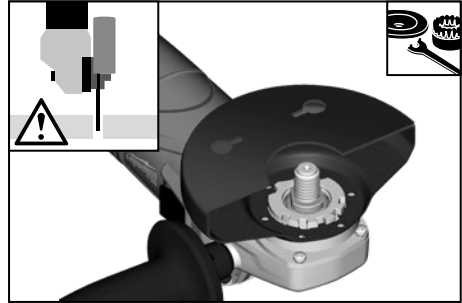
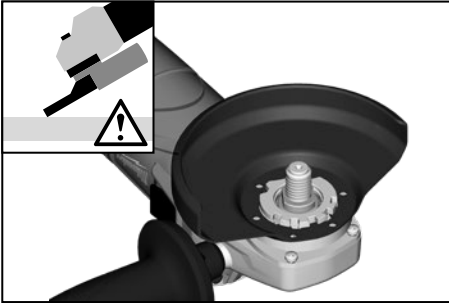

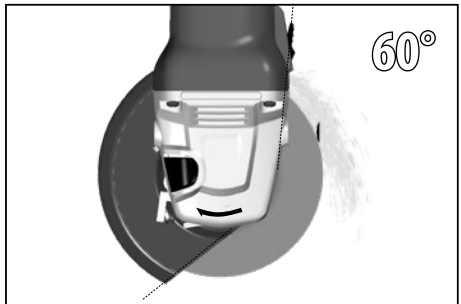
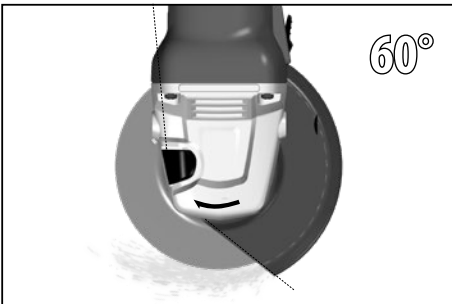
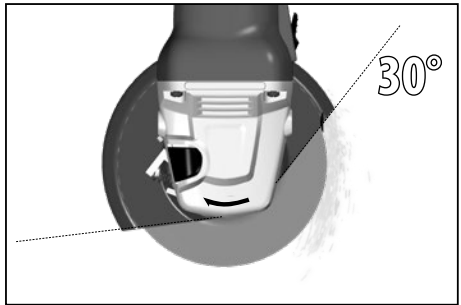
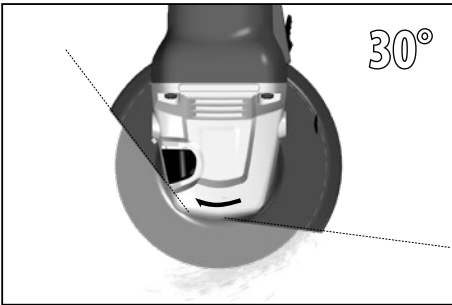
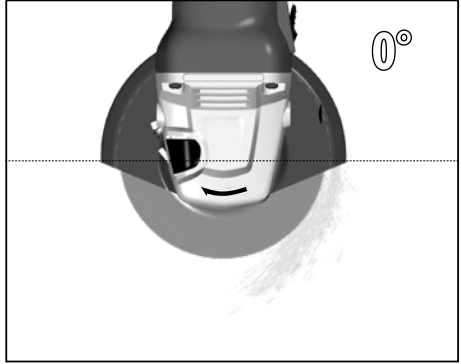
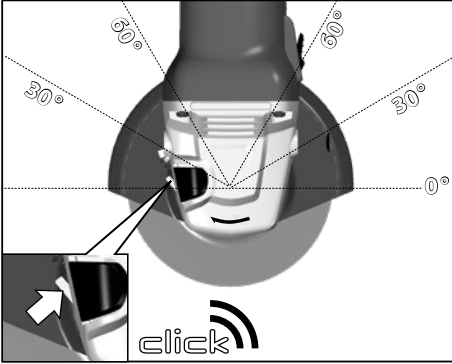
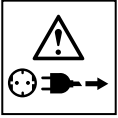
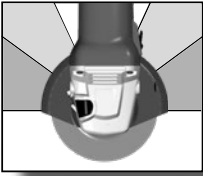

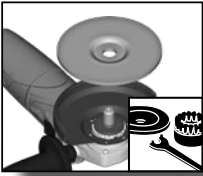

AG 1000-125 EK

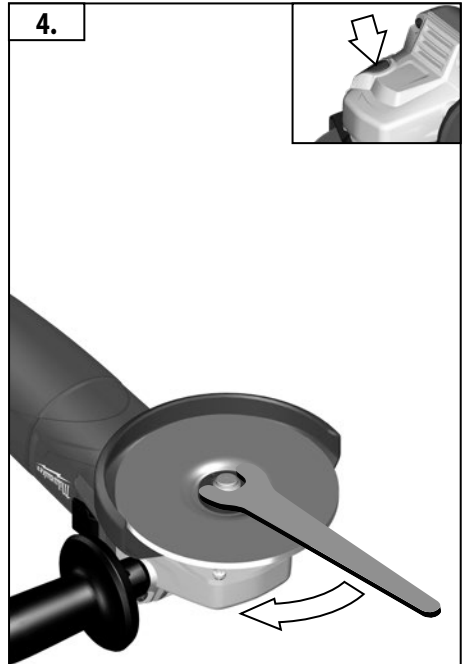
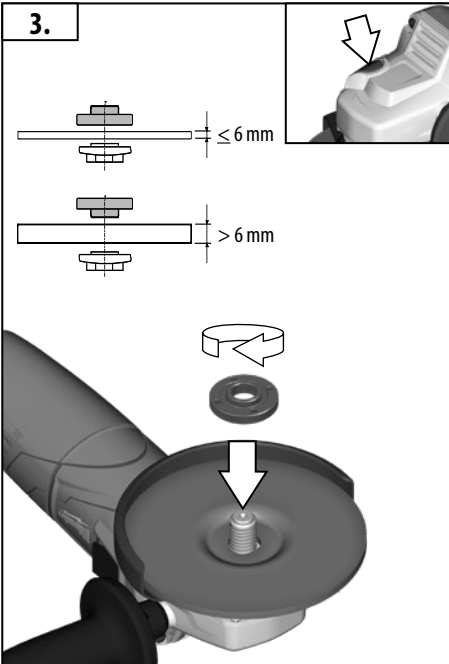
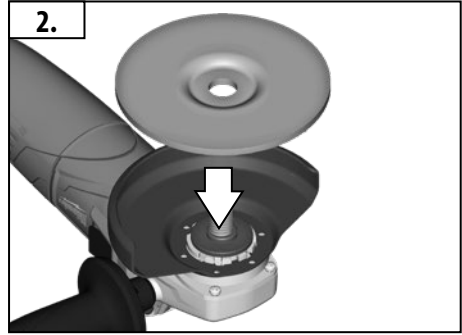
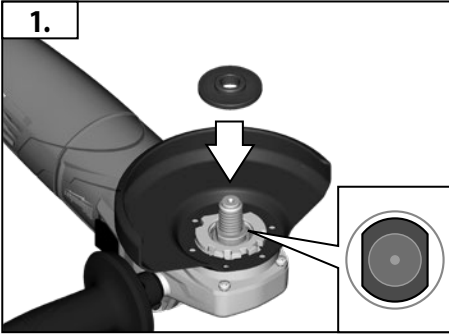

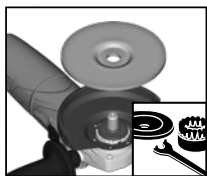

AG 1000-125 EK

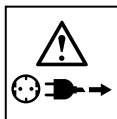

1.

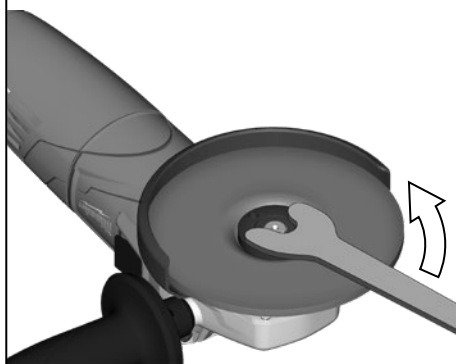

2.

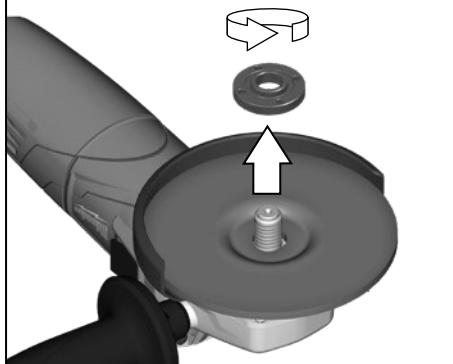

3.

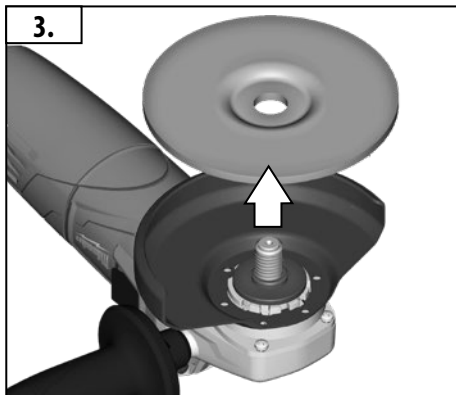

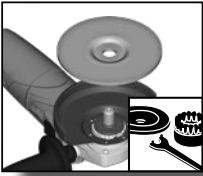

**FIX
TEC**

AG 1000-125 EKX

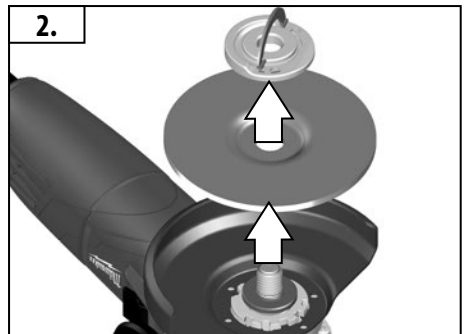
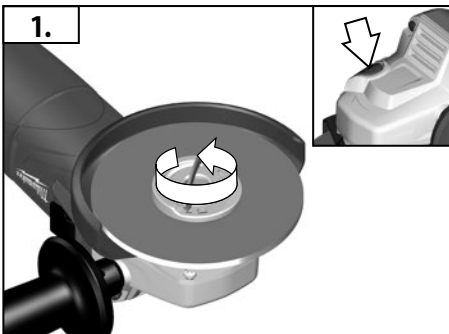
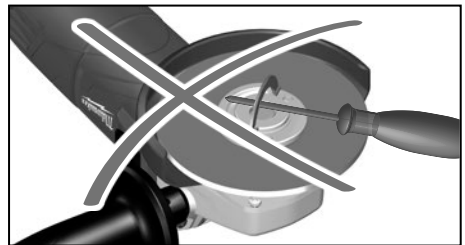
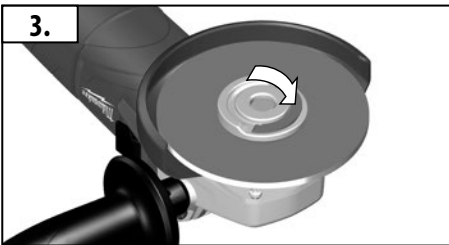
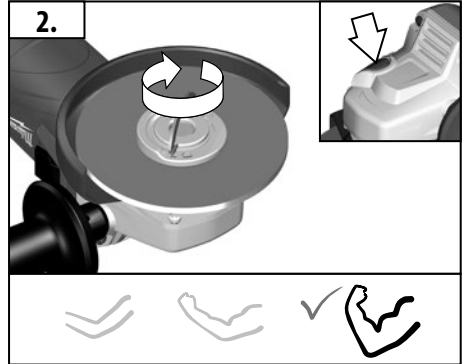
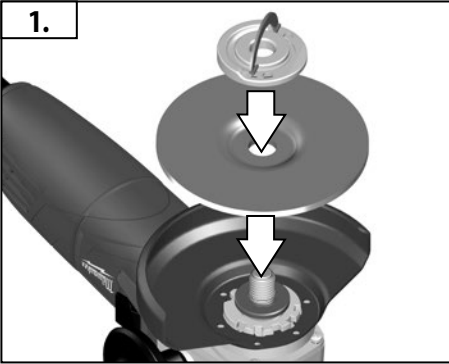



START
STOP
◀

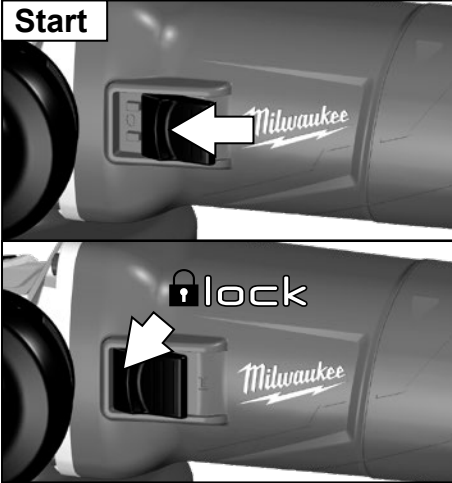

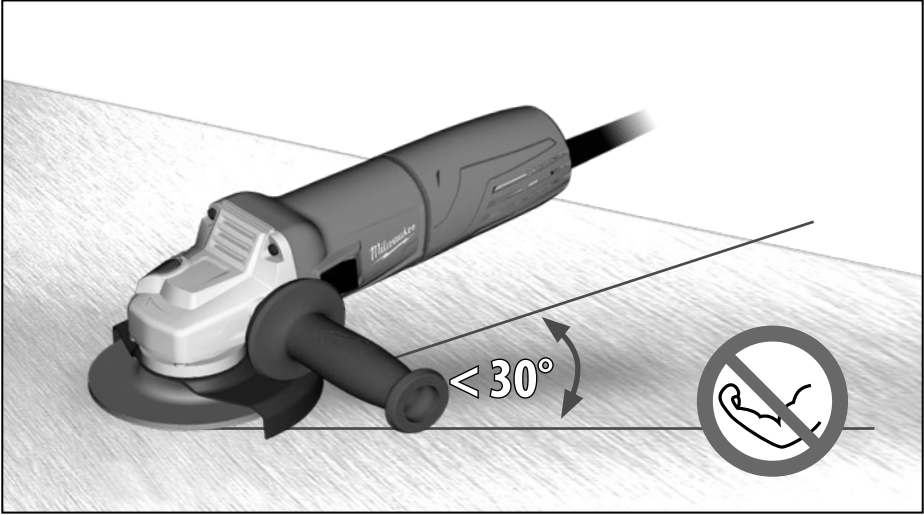
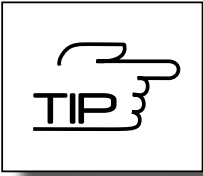

VI

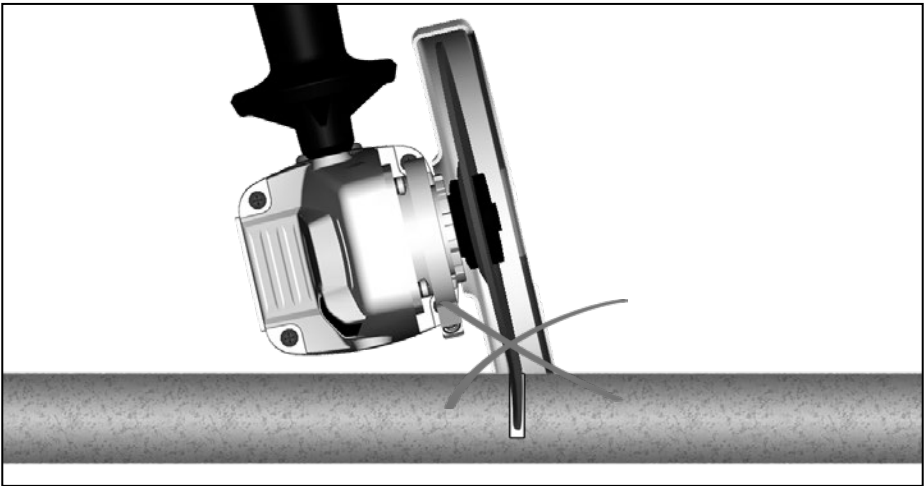

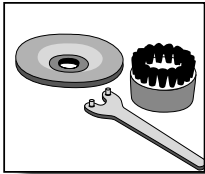

Accessory

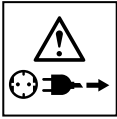



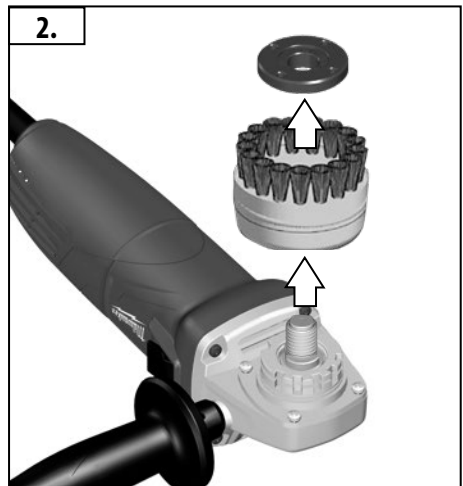
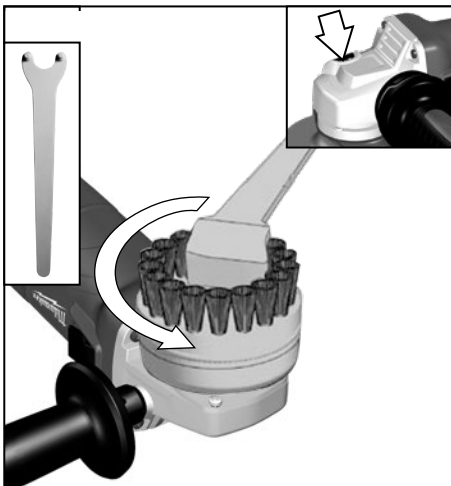
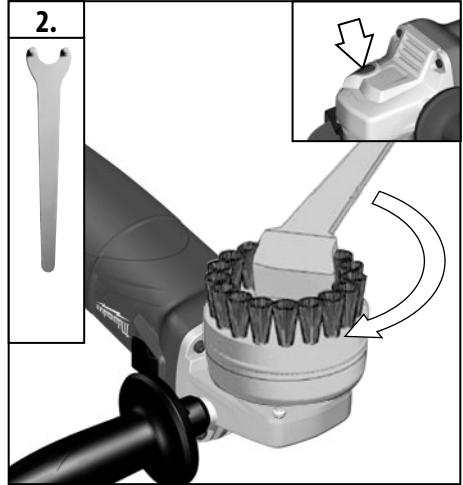
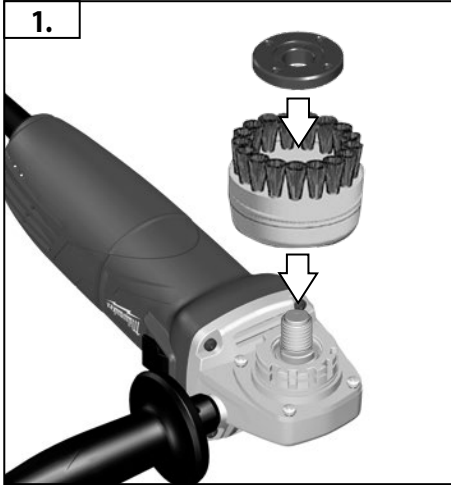

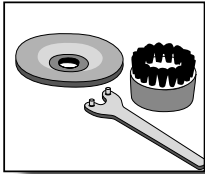
VII



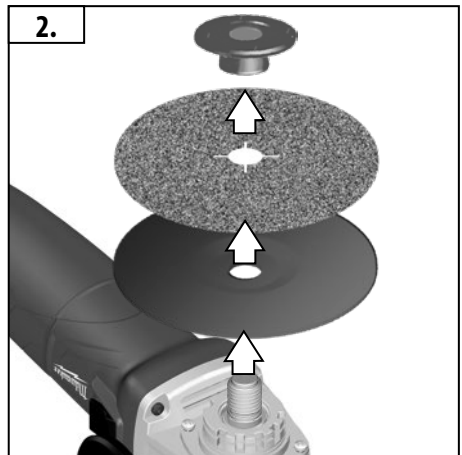
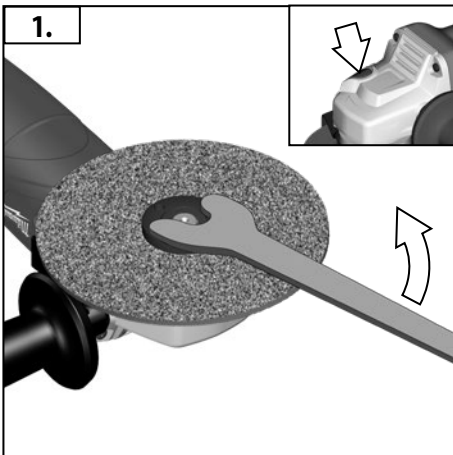
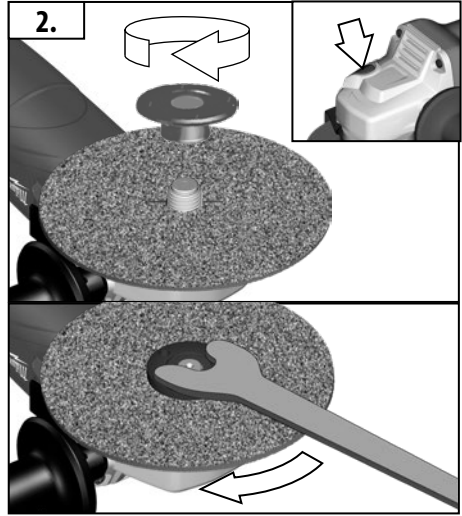
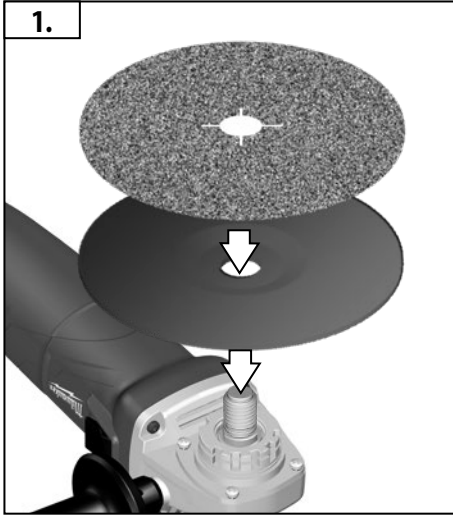
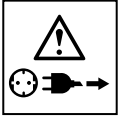

Accessory



TECHNICAL DATA Angle Grinder	AG 1000-125 EK	AG 1000-125 EKX
Production code	4581 63 03... ... 000001-999999	4581 56 03... ... 000001-999999
Rated input	1000 W	1000 W
Rated speed	11000 min ⁻¹	11000 min ⁻¹
D= Grinding disk diameter max. d= Grinding disk hole diameter  b= Cutting disk thickness min. / max.  b= Grinding disk thickness max.  D= Grinding surface diameter max.  D= Wiring brush diameter max.	125 mm 22,2 mm 1 / 3 mm 6 mm 115 mm 75 mm	125 mm 22,2 mm 1 / 3 mm 6 mm 115 mm 75 mm
Thread of work spindle	M 14	M 14
Weight according EPTA-Procedure 01/2014	2,1 kg	2,1 kg
Noise information		
Measured values determined according to EN 60745. Typically, the A-weighted noise levels of the tool are:		
Sound pressure level (Uncertainty K=3dB(A))	89,0 dB (A)	89,0 dB (A)
Sound power level (Uncertainty K=3dB(A))	100,0 dB (A)	100,0 dB (A)
Wear ear protectors!		
Vibration information		
Vibration total values (triaxial vector sum) determined according to EN 60745		
Surface grinding: Vibration emission value $a_{h,SG}$ Uncertainty K=	7,8 m/s ² 1,5 m/s ²	7,8 m/s ² 1,5 m/s ²
Disk sanding: Vibration emission value $a_{h,DS}$ Uncertainty K=	2,6 m/s ² 1,5 m/s ²	2,6 m/s ² 1,5 m/s ²

For other applications, e.g. Abrasive Cutting-Off Operations or Wire Brushing other vibration values could occur.

WARNING!

The vibration emission level given in this information sheet has been measured in accordance with a standardised test given in EN 60745 and may be used to compare one tool with another. It may be used for a preliminary assessment of exposure.

The declared vibration emission level represents the main applications of the tool. However if the tool is used for different applications, with different accessories or poorly maintained, the vibration emission may differ. This may significantly increase the exposure level over the total working period.

An estimation of the level of exposure to vibration should also take into account the times when the tool is switched off or when it is running but not actually doing the job. This may significantly reduce the exposure level over the total working period.

Identify additional safety measures to protect the operator from the effects of vibration such as: maintain the tool and the accessories, keep the hands warm, organisation of work patterns.

 **WARNING** Read all safety warnings and all instructions. Failure to follow the warnings and instructions may result in electric shock, fire and/or serious injury.
Save all warnings and instructions for future reference.

ANGLE GRINDER SAFETY WARNINGS

Safety Warnings Common for Grinding, Sanding, Wire Brushing or Abrasive Cutting-Off Operations:

a) **This power tool is intended to function as a grinder, sander, wire brush or cut-off tool. Read all safety warnings, instructions, illustrations and specifications provided with this power tool.** Failure to follow all instructions listed below may result in electric shock, fire and/or serious injury.

b) Operations such as polishing are not recommended to be performed with this power tool. Operations for which the power tool was not designed may create a hazard and cause personal injury.

c) Do not use accessories which are not specifically designed and recommended by the tool manufacturer. Just because the accessory can be attached to your power tool, it does not assure safe operation.

d) The rated speed of the accessory must be at least equal to the maximum speed marked on the power tool. Accessories running faster than their rated speed can break and fly apart.

e) The outside diameter and the thickness of your accessory must be within the capacity rating of your power tool. Incorrectly sized accessories cannot be adequately guarded or controlled.

f) Threaded mounting of accessories must match the grinder spindle thread. For accessories mounted by flanges, the arbour hole of the accessory must fit the locating diameter of the flange. Accessories that do not match the mounting hardware of the power tool will run out of balance, vibrate excessively and may cause loss of control.

g) Do not use a damaged accessory. Before each use inspect the accessory such as abrasive wheels for chips and cracks, backing pad for cracks, tear or excess wear, wire brush for loose or cracked wires. If power tool or accessory is dropped, inspect for damage or install an undamaged accessory. After inspecting and installing an accessory, position yourself and bystanders away from the plane of the rotating accessory and run the power tool at maximum no-load speed for one minute. Damaged accessories will normally break apart during this test time.

h) Wear personal protective equipment. Depending on application, use face shield, safety goggles or safety glasses. As appropriate, wear dust mask, hearing protectors, gloves and shop apron capable of stopping small abrasive or workpiece fragments. The eye protection must be capable of stopping flying debris generated by various operations. The dust mask or respirator must be capable of filtering particles generated by your operation. Prolonged exposure to high intensity noise may cause hearing loss.

i) Keep bystanders a safe distance away from work area. Anyone entering the work area must wear personal protective equipment. Fragments of workpiece or of a broken accessory may fly away and cause injury beyond immediate area of operation.

j) Hold the power tool by insulated gripping surfaces only, when performing an operation where the cutting accessory may contact hidden wiring or its own cord. Cutting accessory contacting a "live" wire may make exposed metal parts of the power tool "live" and could give the operator an electric shock.

k) Position the cord clear of the spinning accessory. If you lose control, the cord may be cut or snagged and your hand or arm may be pulled into the spinning wheel.

l) Never lay the power tool down until the accessory has come to a complete stop. The spinning accessory may grab the surface and pull the power tool out of your control.

m) Do not run the power tool while carrying it at your side. Accidental contact with the spinning accessory could snag your clothing, pulling the accessory into your body.

n) Regularly clean the power tool's air vents. The motor's fan will draw the dust inside the housing and excessive accumulation of

powdered metal may cause electrical hazards.

o) Do not operate the power tool near flammable materials. Sparks could ignite these materials.

p) Do not use accessories that require liquid coolants. Using water or other liquid coolants may result in electrocution or shock.

Kickback and Related Warnings

Kickback is a sudden reaction to a pinched or snagged rotating wheel, backing pad, brush or any other accessory. Pinching or snagging causes rapid stalling of the rotating accessory which in turn causes the uncontrolled power tool to be forced in the direction opposite of the accessory's rotation at the point of the binding.

For example, if an abrasive wheel is snagged or pinched by the workpiece, the edge of the wheel that is entering into the pinch point can dig into the surface of the material causing the wheel to climb out or kick out. The wheel may either jump toward or away from the operator, depending on direction of the wheel's movement at the point of pinching. Abrasive wheels may also break under these conditions.

Kickback is the result of power tool misuse and/or incorrect operating procedures or conditions and can be avoided by taking proper precautions as given below.

a) Maintain a firm grip on the power tool and position your body and arm to allow you to resist kickback forces. Always use auxiliary handle, if provided, for maximum control over kickback or torque reaction during start-up. The operator can control torque reactions or kickback forces, if proper precautions are taken.

b) Never place your hand near the rotating accessory. Accessory may kickback over your hand.

c) Do not position your body in the area where power tool will move if kickback occurs. Kickback will propel the tool in direction opposite to the wheel's movement at the point of snagging.

d) Use special care when working corners, sharp edges etc. Avoid bouncing and snagging the accessory. Corners, sharp edges or bouncing have a tendency to snag the rotating accessory and cause loss of control or kickback.

e) Do not attach a saw chain woodcarving blade or toothed saw blade. Such blades create frequent kickback and loss of control.

Safety Warnings Specific for Grinding and Abrasive Cutting-Off Operations:

a) Use only wheel types that are recommended for your power tool and the specific guard designed for the selected wheel. Wheels for which the power tool was not designed cannot be adequately guarded and are unsafe.

b) The grinding surface of the centre depressed wheels must be mounted below the plane of the guard lip. An improperly mounted wheel that projects through the plane of the guard lip cannot be adequately protected.

c) The guard must be securely attached to the power tool and positioned for maximum safety, so the least amount of wheel is exposed towards the operator. The guard helps to protect the operator from broken wheel fragments, accidental contact with wheel and sparks that could ignite clothing.

d) Wheels must be used only for recommended applications. For example: do not grind with the side of cut-off wheel. Abrasive cut-off wheels are intended for peripheral grinding, side forces applied to these wheels may cause them to shatter.



e) Always use undamaged wheel flanges that are of correct size and shape for your selected wheel. Proper wheel flanges support the wheel thus reducing the possibility of wheel breakage. Flanges for cut-off wheels may be different from grinding wheel flanges.

f) Do not use worn down wheels from larger power tools. Wheel intended for larger power tool is not suitable for the higher speed of a smaller tool and may burst.

Additional Safety Warnings Specific for Abrasive Cutting-Off Operations:

a) Do not "jam" the cut-off wheel or apply excessive pressure. Do not attempt to make an excessive depth of cut. Overstressing the wheel increases the loading and susceptibility to twisting or binding of the wheel in the cut and the possibility of kickback or wheel breakage.

b) Do not position your body in line with and behind the rotating wheel. When the wheel, at the point of operation, is moving away from your body, the possible kickback may propel the spinning wheel and the power tool directly at you.

c) When wheel is binding or when interrupting a cut for any reason, switch off the power tool and hold the power tool motionless until the wheel comes to a complete stop. Never attempt to remove the cut-off wheel from the cut while the wheel is in motion otherwise kickback may occur. Investigate and take corrective action to eliminate the cause of wheel binding.

d) Do not restart the cutting operation in the workpiece. Let the wheel reach full speed and carefully re-enter the cut. The wheel may bind, walk up or kickback if the power tool is restarted in the workpiece.

e) Support panels or any oversized workpiece to minimize the risk of wheel pinching and kickback. Large workpieces tend to sag under their own weight. Supports must be placed under the workpiece near the line of cut and near the edge of the workpiece on both sides of the wheel.

f) Use extra caution when making a "pocket cut" into existing walls or other blind areas. The protruding wheel may cut gas or water pipes, electrical wiring or objects that can cause kickback.

Safety Warnings Specific for Sanding Operations:

a) Do not use excessively oversized sanding disc paper. Follow manufacturers recommendations, when selecting sanding paper. Larger sanding paper extending beyond the sanding pad presents a laceration hazard and may cause snagging, tearing of the disc or kickback.

Safety Warnings Specific for Wire Brushing Operations:

a) Be aware that wire bristles are thrown by the brush even during ordinary operation. Do not overstress the wires by applying excessive load to the brush. The wire bristles can easily penetrate light clothing and/or skin.

b) If the use of a guard is recommended for wire brushing, do not allow any interference of the wire wheel or brush with the guard. Wire wheel or brush may expand in diameter due to work load and centrifugal forces.

Additional Safety and Working Instructions

When grinding metal, flying sparks are produced. Take care that no persons are endangered. Because of the danger of fire, no combustible materials should be located in the vicinity (spark flight zone). Do not use dust extraction.

Avoid flying sparks and sanding dust hit your body.

Never reach into the danger area of the machine when it is running. Immediately switch off the machine in case of considerable vibrations or if other malfunctions occur. Check the machine in order to find out the cause.

Under extreme conditions (e.g. smooth-grinding metals with the arbour and vulcanized fibre grinding disk), significant contamination can build up on the inside of the angle grinder. For safety reasons, in such conditions a ground fault interrupter must be connected in series. If the ground fault interrupter trips the machine must be sent for service.

Chips and splinters must not be removed while the machine is running.

MAINS CONNECTION

Connect only to single-phase AC system voltage as indicated on the rating plate. It is also possible to connect to sockets without an earthing contact as the design conforms to safety class II.

Appliances used at many different locations including wet room and open air must be connected via a residual current device (FI, RCD, PRCD) of 30mA or less.

Only plug-in when machine is switched off.

Do not let any metal parts enter the airing slots - danger of short circuit!

Inrush currents cause short-time voltage drops. Under unfavourable power supply conditions, other equipment may be affected. If the system impedance of the power supply is lower than 0,2 Ohm, disturbances are unlikely to occur.

SPECIFIED CONDITIONS OF USE

The angle grinder is intended for grinding and cutting metal, stone and ceramic materials as well as sanding and wire brushing.

Use the cutting guard from the accessories range for cutting application.

Please refer to the instructions supplied by the accessory manufacturer.

The machine is suitable only for working without water.

WORKING INSTRUCTIONS

For accessories intended to be fitted with threaded hole wheel, ensure that the thread in the wheel is long enough to accept the spindle length.

Always use and store the cutting and grinding disks according to the manufacturer's instructions.

Always use the correct guard for cutting and grinding.

The grinding surface of the centre depressed disks must be mounted min. 2 mm below the plane of the guard lip.

The adjusting nut must be tightened before starting to work with the machine.

Always use the auxiliary handle.

The workpiece must be fixed if it is not heavy enough to be steady. Never move the workpiece towards the rotating disk by hand.

ELECTRONICS

Machines with a lockable switch are supplied with a restart cutout. This prevents the machine restarting by itself after a power failure. When resuming work, switch the machine off and then switch it back on again.

The device has an overload protection function and will stop if an overload occurs. Machine shut-off. After the machine has cooled down the device can be put back into operation.



SMOOTH START

Electronic smooth start for save use prevents jerky run-up of the machine.

MAINTENANCE

The ventilation slots of the machine must be kept clear at all times. If the replacement of the supply cord is necessary, this has to be done by the manufacturer or his agent in order to avoid a safety hazard.

Use only Milwaukee accessories and Milwaukee spare parts. Should components need to be replaced which have not been described, please contact one of our Milwaukee service agents (see our list of guarantee/ service addresses).

If needed, an exploded view of the tool can be ordered. Please state the Article No. as well as the machine type printed on the label and order the drawing at your local service agents or directly at: Techtronic Industries GmbH, Max-Eyth-Straße 10, 71364 Winnenden, Germany.

EC-DECLARATION OF CONFORMITY

We declare under our sole responsibility that the product described under "Technical Data" fulfills all the relevant provisions of the directives

2011/65/EU (RoHS), 2006/42/EC, 2014/30/EU

and the following harmonized standards have been used.

EN 60745-1:2009 + A11:2010

EN 60745-2-3:2011+A2:2013

EN 55014-1:2017+A11:2020

EN 55014-2:2015

EN 61000-3-2:2014

EN 61000-3-3:2013

EN IEC 63000:2018



Winnenden. 2020-11-12

Alexander Krug / Managing Director
Authorized to compile the technical file

Techtronic Industries GmbH
Max-Eyth-Straße 10, 71364 Winnenden, Germany

GB-DECLARATION OF CONFORMITY

We declare as the manufacturer under our sole responsibility that the product described under „Technical Data“ fulfills all the relevant provisions of the following Regulations

S.I. 2012/3032 (as amended), S.I. 2008/1597 (as amended),

S.I. 2016/1091 (as amended) and that the following designated

standards have been used:

BS EN 60745-1:2009+A11:2010

BS EN 60745-2-3:2011+A13:2015

BS EN 55014-1:2017+A11:2020

BS EN 55014-2:2015

BS EN 61000-3-2:2014

BS EN 61000-3-3:2013

BS EN IEC 63000:2018

Winnenden. 2020-11-12

Alexander Krug / Managing Director
Authorized to compile the technical file

Techtronic Industries GmbH
Max-Eyth-Straße 10, 71364 Winnenden, Germany

SYMBOLS



CAUTION! WARNING! DANGER!



Please read the instructions carefully before starting the machine.



Always wear goggles when using the machine.



Wear gloves!



Always disconnect the plug from the socket before carrying out any work on the machine.



Do not use force.



Only for cutting work.



Only for grinding.



Accessory - Not included in standard equipment, available as an accessory.



Do not dispose of electric tools together with household waste material. Electric tools and electronic equipment that have reached the end of their life must be collected separately and returned to an environmentally compatible recycling facility. Check with your local authority or retailer for recycling advice and collection point.



Class II tool. Tool in which protection against electric shock does not rely on basic insulation only, but in which additional safety precautions, such as double insulation or reinforced insulation, are provided. There being no provision for protective earthing or reliance upon installation conditions.



European Conformity Mark



British Conformity Mark



Ukraine Conformity Mark



EurAsian Conformity Mark



Copyright 2020
Techtronic Industries GmbH
Max-Eyth-Straße 10
71364 Winnenden
Germany
+49 (0) 7195-12-0
www.milwaukeeetool.eu

Techtronic Industries (UK) Ltd
Fieldhouse Lane
Marlow Bucks SL7 1HZ
UK



(11.20)

4100 4250 37