

Milwaukee[®]

Nothing but **HEAVY DUTY**.[®]



M18 CCS66

Original instructions

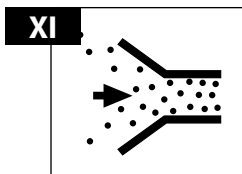
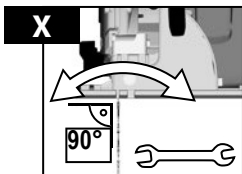
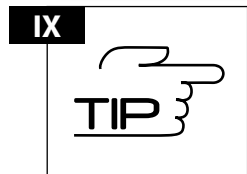
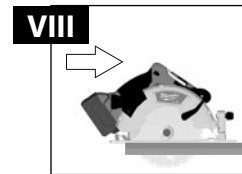
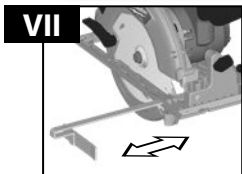
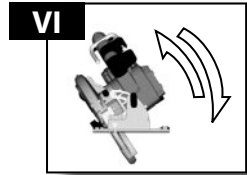
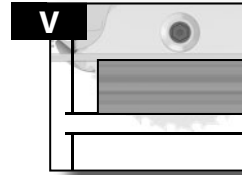
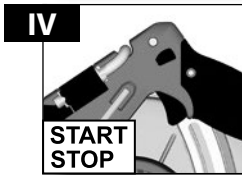
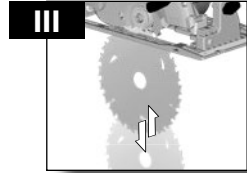
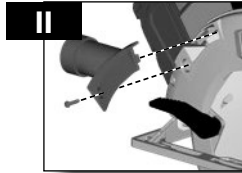
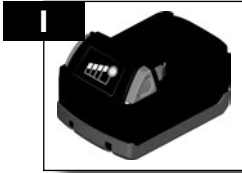

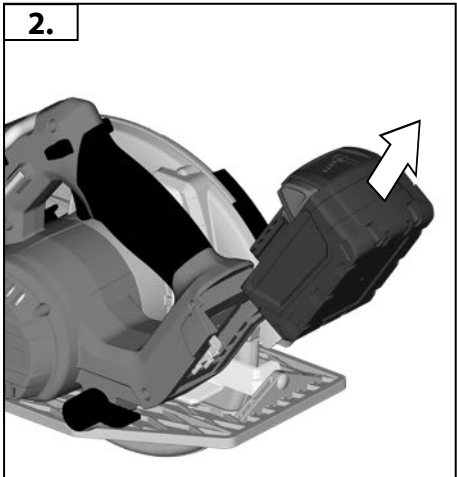
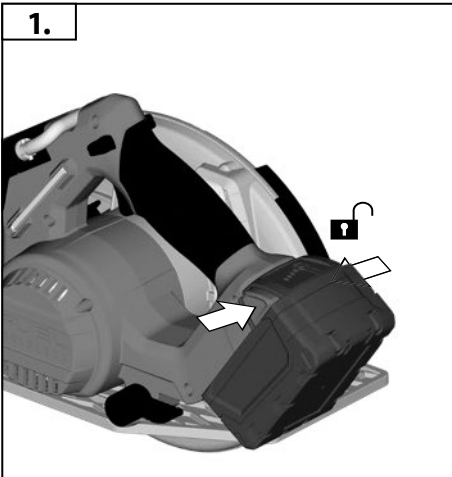
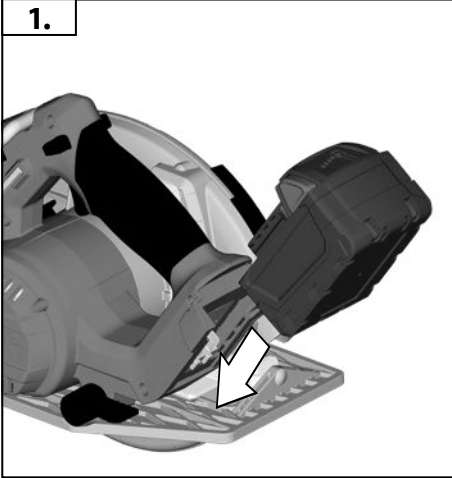

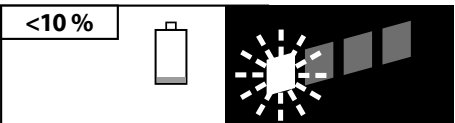
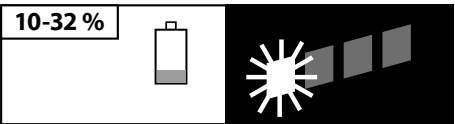
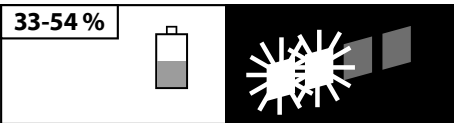
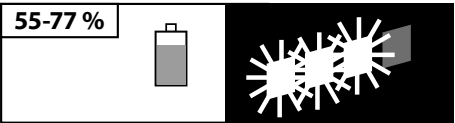
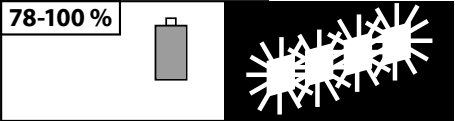
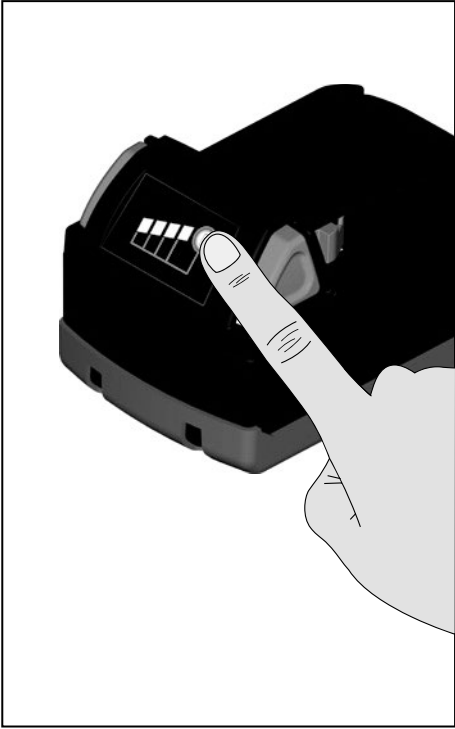

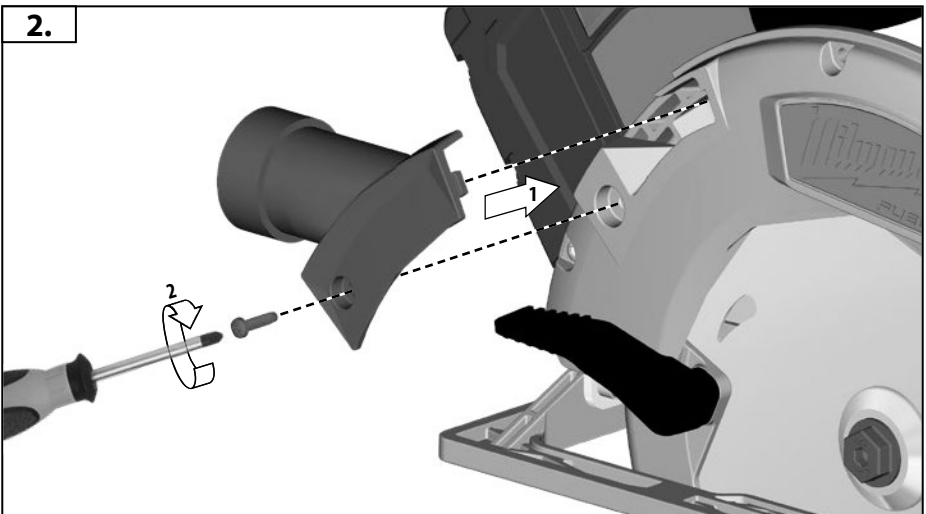
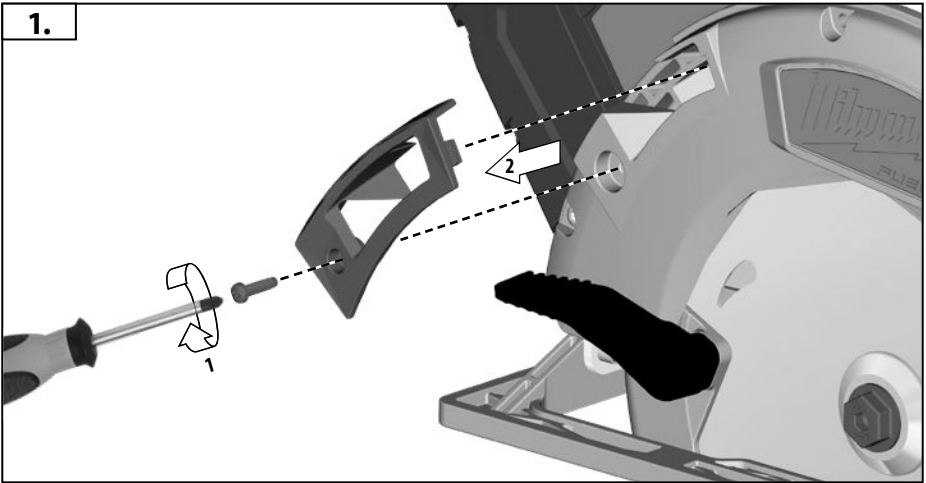
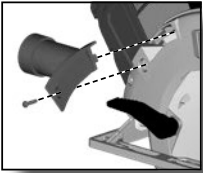

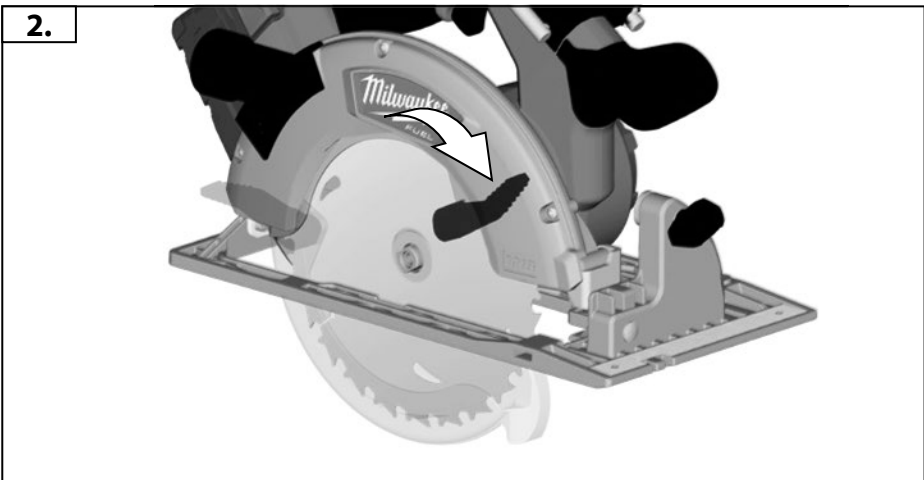
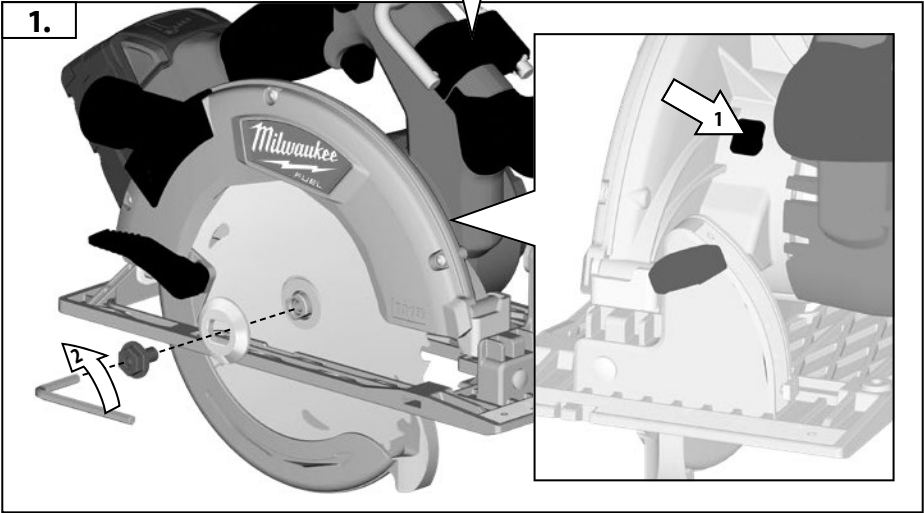
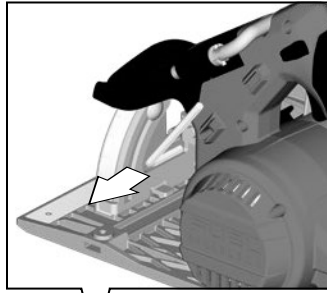
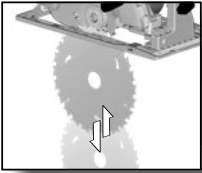

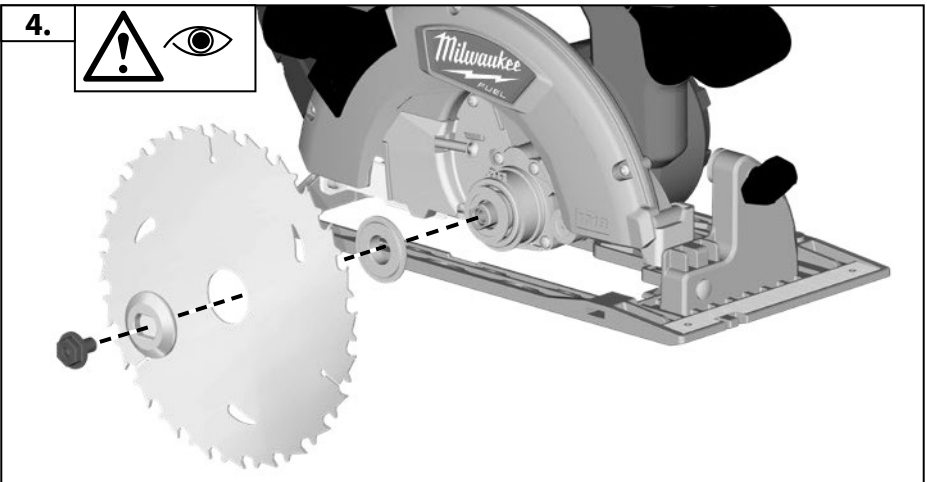
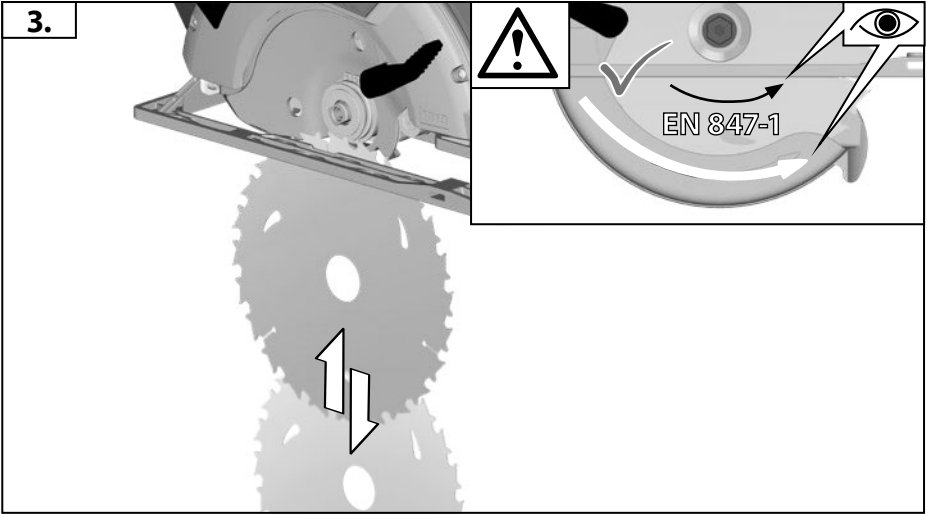
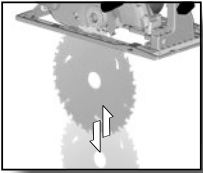

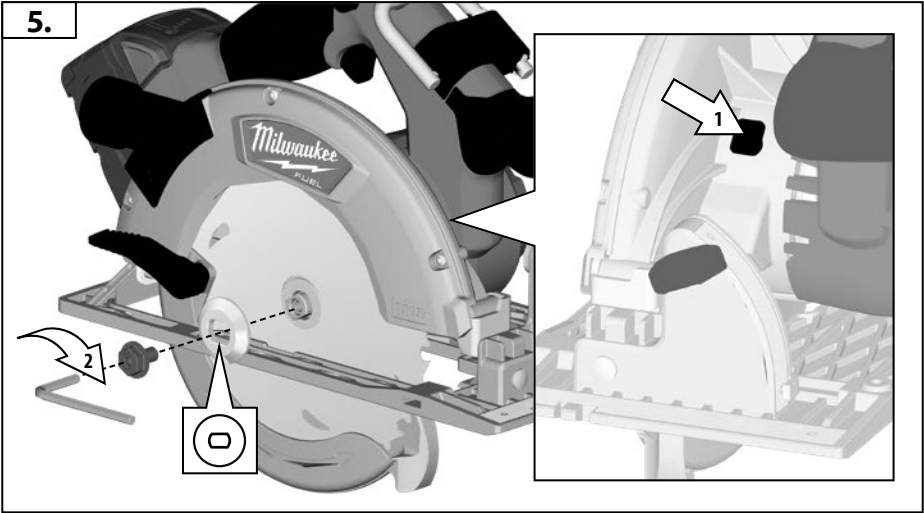
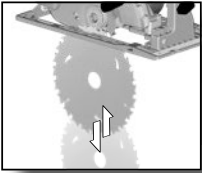

III

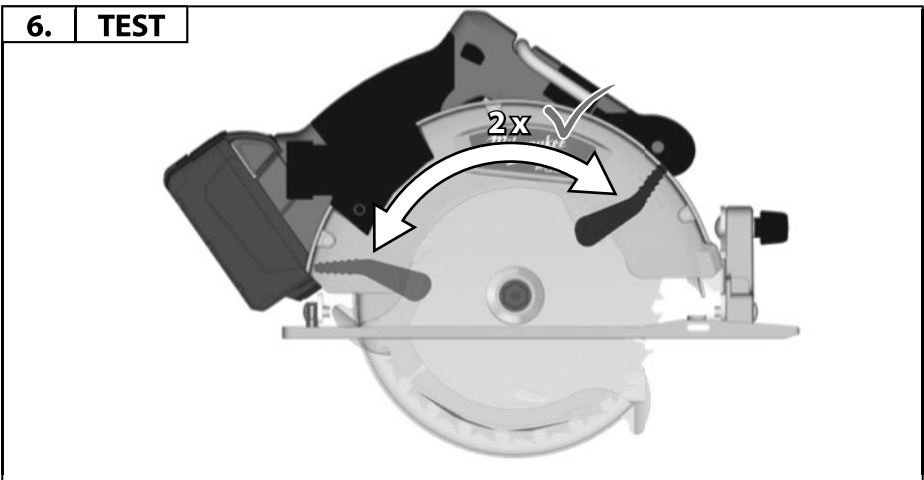



START
STOP
≡

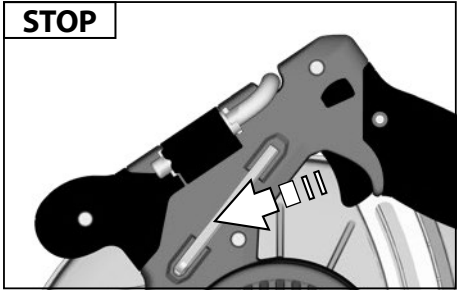
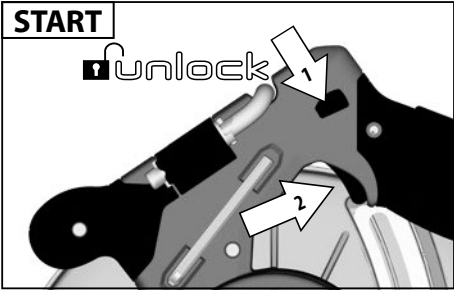

For safety reasons this power tool is fitted with a switch lock and the On-/Off switch cannot be locked in the „On“ position.



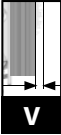
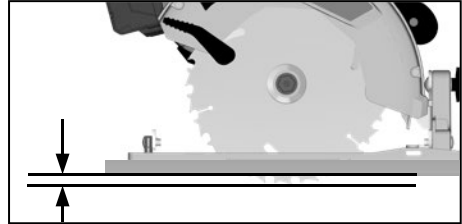
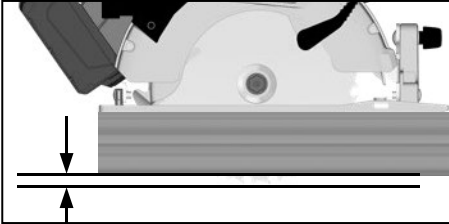
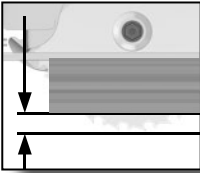

Adjust the cutting depth to the thickness of the workpiece. Less than a full tooth of the blade teeth should be visible below the workpiece.

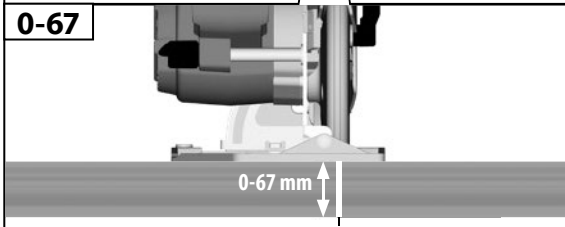
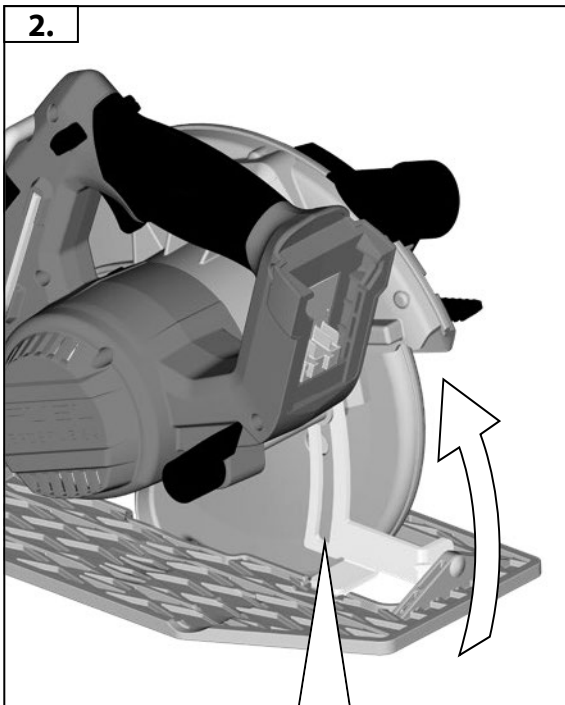
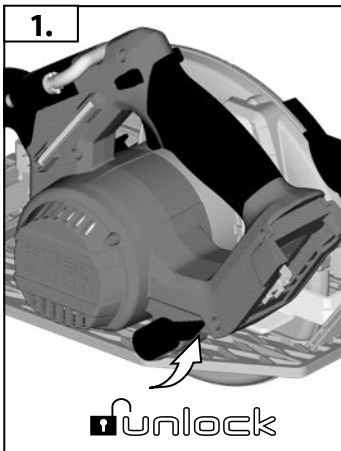
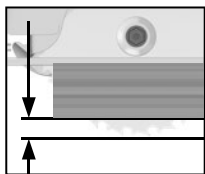

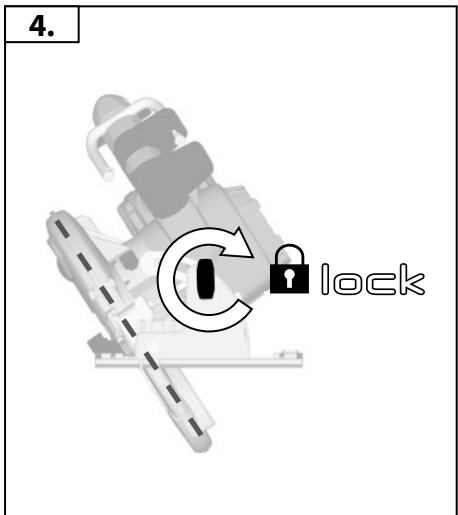
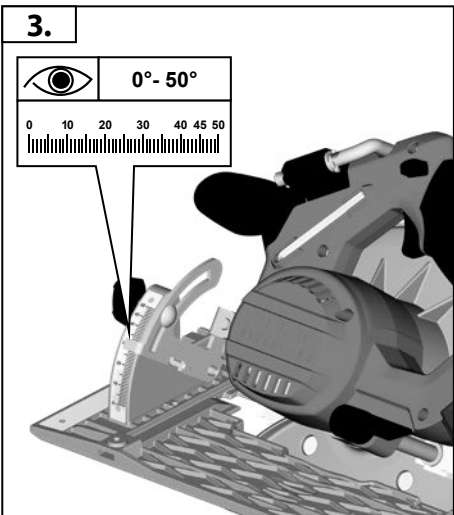
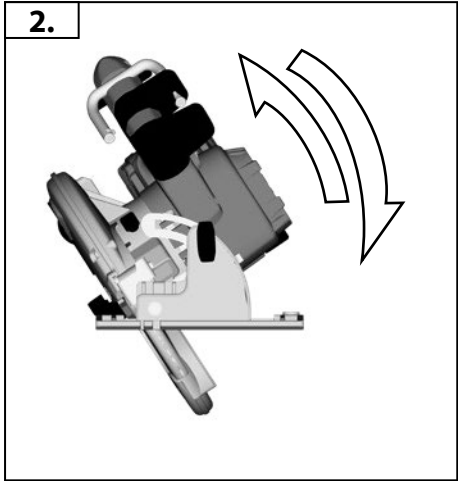
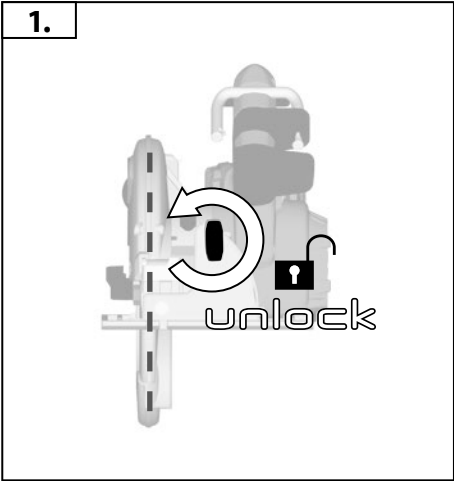
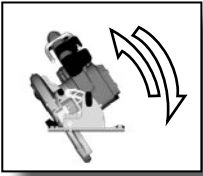

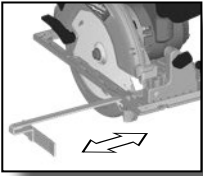

VII

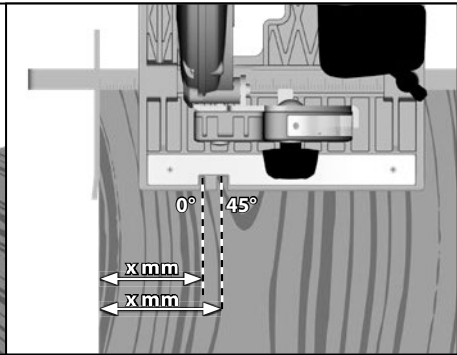
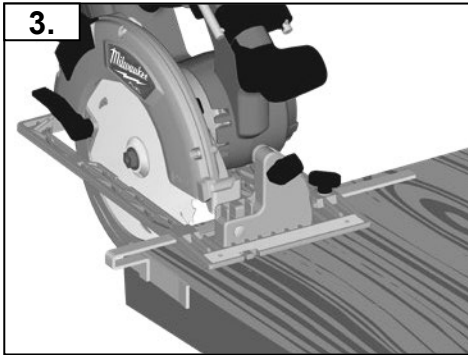
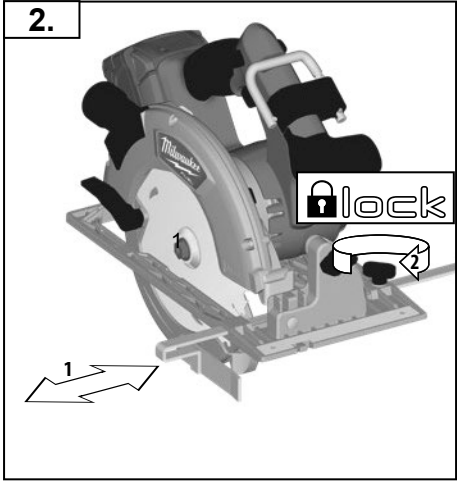
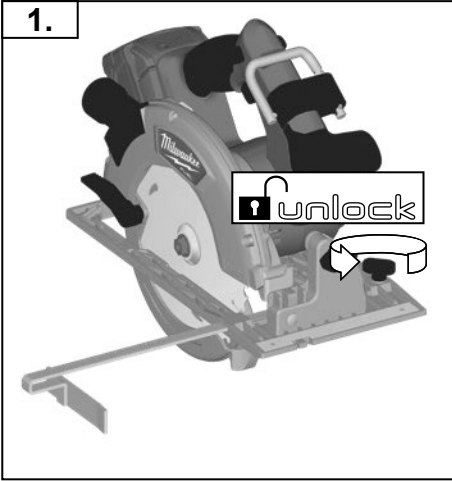

Carry out a test cut

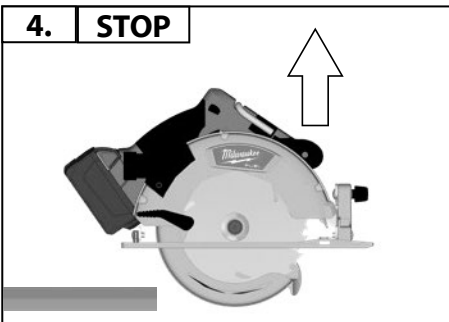
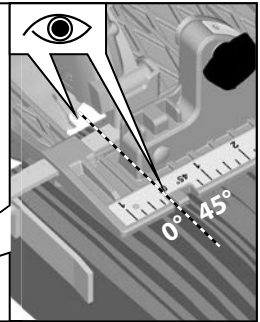
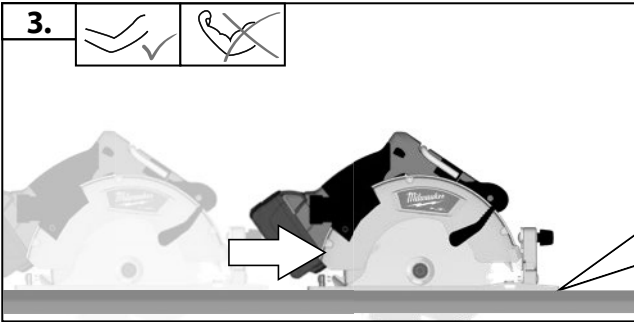
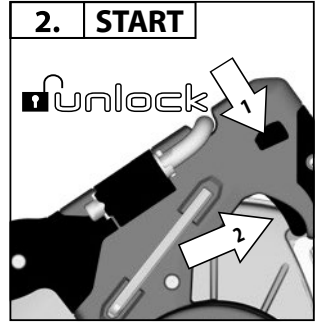
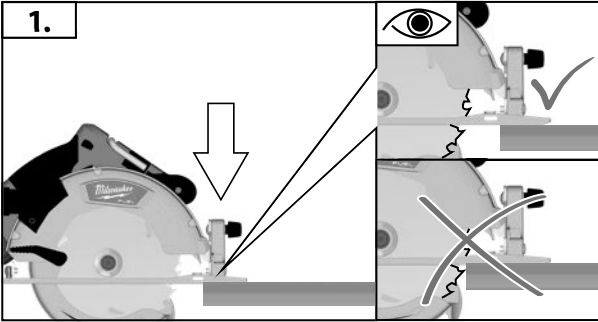
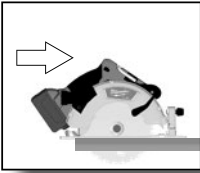

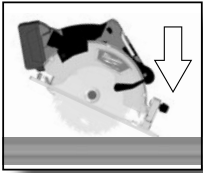

TIP
IX

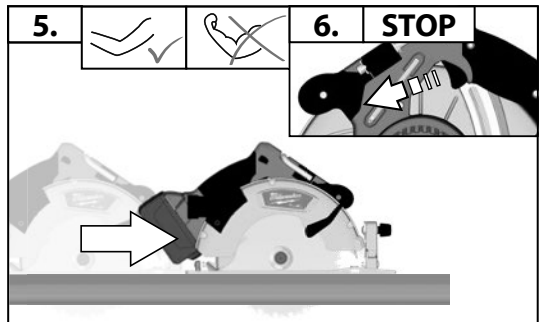
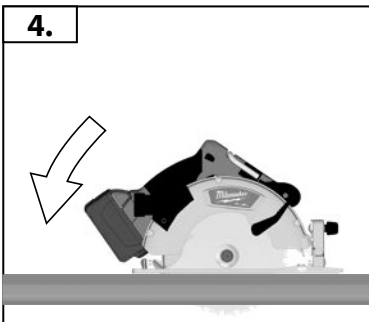
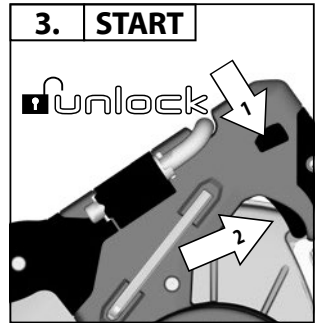
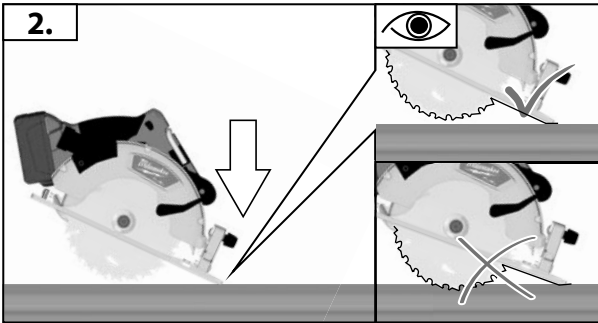
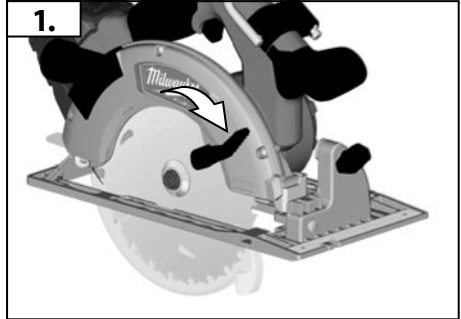
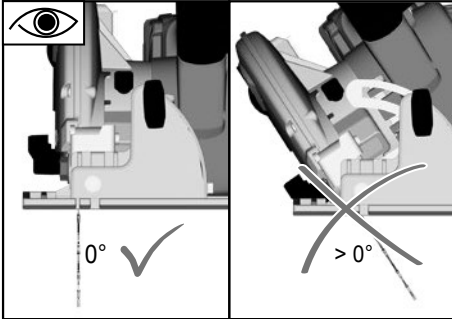

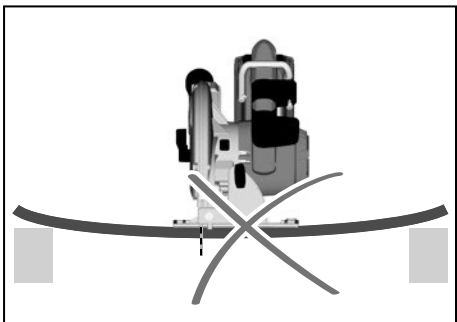
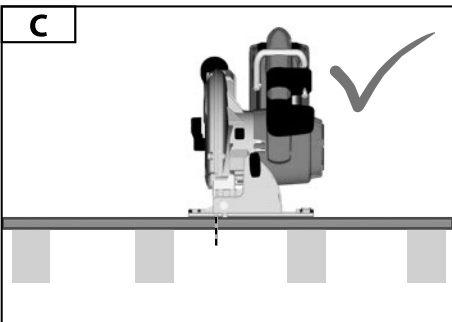
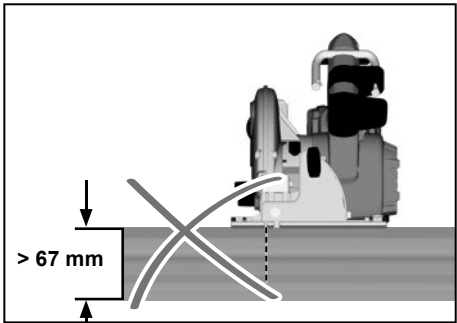
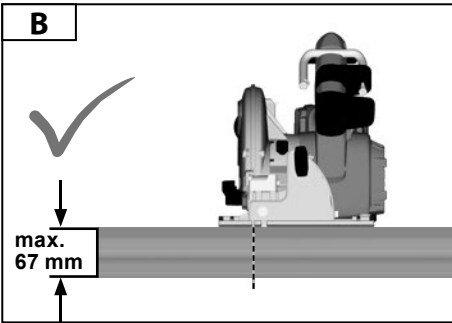
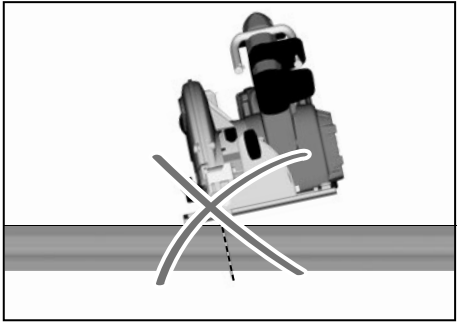
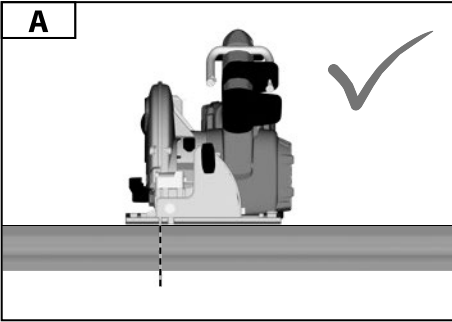
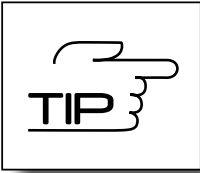

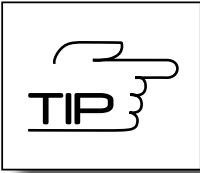

TIP
IX

1.



2.



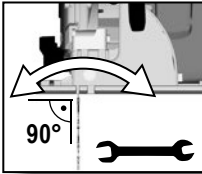

If a correction of the 90° angle of the guide-plate to the saw blade is necessary, use the correction screw.

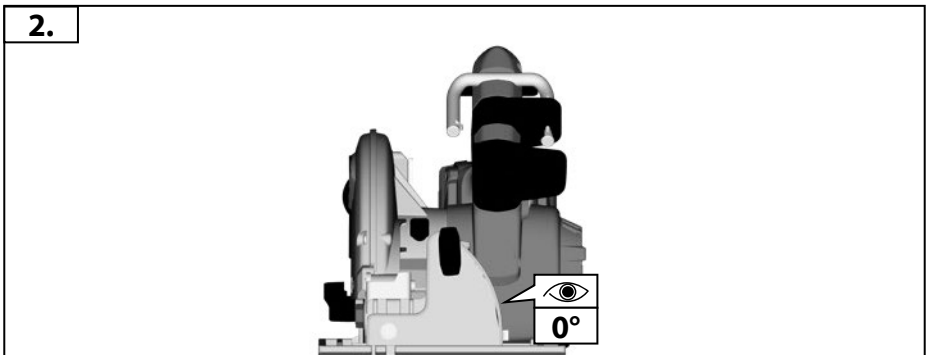
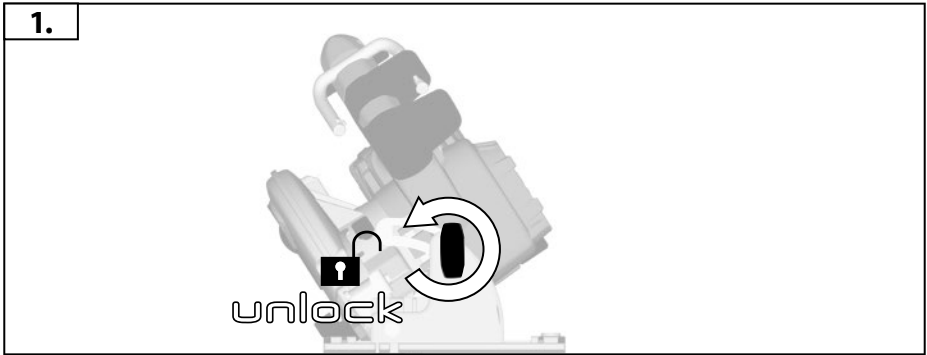

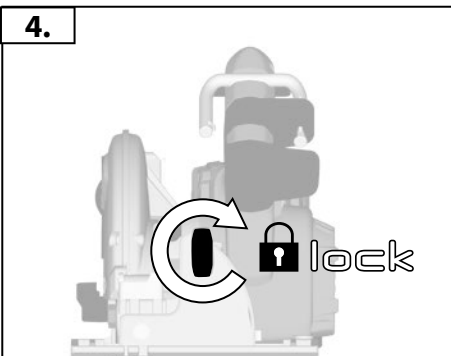
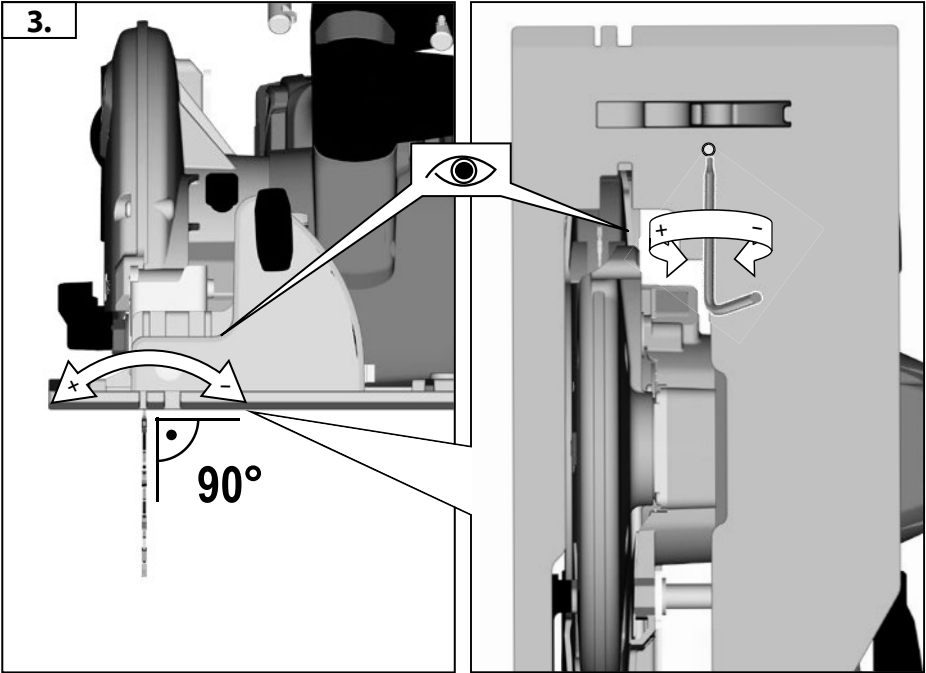
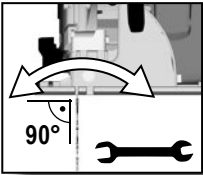

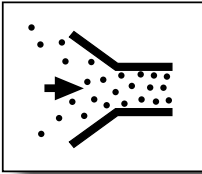

A	AS 2-250	4931 4472 95
B	AS 300 / 500	4931 4472 94

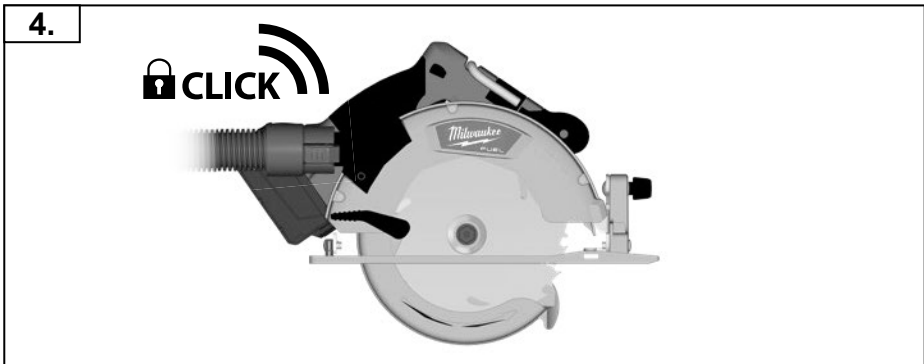
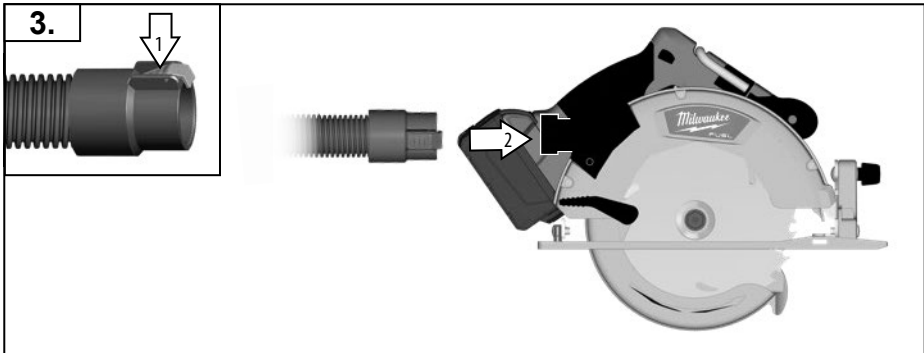
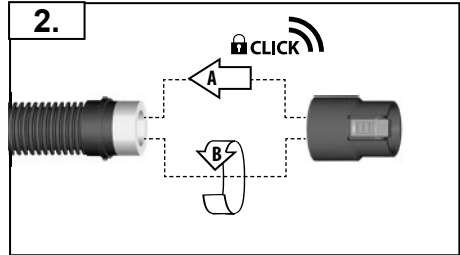
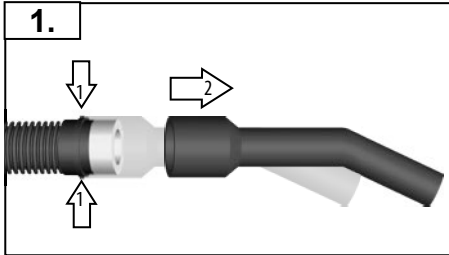

TECHNICAL DATA Circular saw	M18 CCS66
Production code	4472 56 05 000001-999999
No-load speed	5000 min ⁻¹
Saw blade dia. x hole dia	190 x 30 mm
Saw blade thickness	2,0 mm
Max. Cutting depth at 0° / 45° / 50°	67 / 48 / 46 mm
Battery voltage	18 V
Weight according EPTA-Procedure 01/2014 (4,0 Ah)	4,2 kg
Noise information Measured values determined according to EN 60745. Typically, the A-weighted noise levels of the tool are:	
Sound pressure level (Uncertainty K=3dB(A))	83,2 dB(A)
Sound power level (Uncertainty K=3dB(A))	94,2 dB(A)
Wear ear protectors!	
Vibration information Vibration total values (triaxial vector sum) determined according to EN 60745	
Sawing of wood Vibration emission value a _{h,w}	2,0 m/s ²
Uncertainty K=	1,5 m/s ²



WARNING

The vibration emission level given in this information sheet has been measured in accordance with a standardised test given in EN 60745 and may be used to compare one tool with another. It may be used for a preliminary assessment of exposure.

The declared vibration emission level represents the main applications of the tool. However if the tool is used for different applications, with different accessories or poorly maintained, the vibration emission may differ. This may significantly increase the exposure level over the total working period.

An estimation of the level of exposure to vibration should also take into account the times when the tool is switched off or when it is running but not actually doing the job. This may significantly reduce the exposure level over the total working period.

Identify additional safety measures to protect the operator from the effects of vibration such as: maintain the tool and the accessories, keep the hands warm, organisation of work patterns.

WARNING!

Read all safety warnings, instructions, illustrations and specifications provided with this power tool. Failure to follow the warnings and instructions may result in electric shock, fire and/or serious injury.

Save all warnings and instructions for future reference.

CIRCULAR SAW SAFETY WARNINGS

Cutting procedures

-  DANGER: Keep hands away from cutting area and the blade. Keep your second hand on auxiliary handle, or motor housing.** If both hands are holding the saw, they cannot be cut by the blade.
- Do not reach underneath the workpiece.** The guard cannot protect you from the blade below the workpiece.
- Adjust the cutting depth to the thickness of the workpiece.** Less than a full tooth of the blade teeth should be visible below the workpiece.
- Never hold the workpiece in your hands or across your leg while cutting. Secure the workpiece to a stable platform.** It is important to support the work properly to minimise body exposure, blade binding, or loss of control.

e) **Hold the power tool by insulated gripping surfaces, when performing an operation where the cutting tool may contact hidden wiring.** Contact with a „live“ wire will also make exposed metal parts of the power tool „live“ and could give the operator an electric shock.

f) **When ripping, always use a rip fence or straight edge guide.** This improves the accuracy of cut and reduces the chance of blade binding.

g) **Always use blades with correct size and shape (diamond versus round) of arbour holes.** Blades that do not match the mounting hardware of the saw will run off-centre, causing loss of control.

h) **Never use damaged or incorrect blade washers or bolt.** The blade washers and bolt were specially designed for your saw, for optimum performance and safety of operation.

Kickback causes and related warnings

– kickback is a sudden reaction to a pinched, jammed or misaligned saw blade, causing an uncontrolled saw to lift up and out of the workpiece toward the operator;

– when the blade is pinched or jammed tightly by the kerf closing down, the blade stalls and the motor reaction drives the unit rapidly back toward the operator;

– if the blade becomes twisted or misaligned in the cut, the teeth at the back edge of the blade can dig into the top surface of the wood causing the blade to climb out of the kerf and jump back toward the operator.

Kickback is the result of saw misuse and/or incorrect operating procedures or conditions and can be avoided by taking proper precautions as given below.

- a) **Maintain a firm grip with both hands on the saw and position your arms to resist kickback forces. Position your body to either side of the blade, but not in line with the blade.** Kickback could cause the saw to jump backwards, but kickback forces can be controlled by the operator, if proper precautions are taken.
- b) **When blade is binding, or when interrupting a cut for any reason, release the trigger and hold the saw motionless in the material until the blade comes to a complete stop. Never attempt to remove the saw from the work or pull the saw backward while the blade is in motion or kickback may occur.** Investigate and take corrective actions to eliminate the cause of blade binding.
- c) **When restarting a saw in the workpiece, centre the saw blade in the kerf so that the saw teeth are not engaged into the material.** If a saw blade binds, it may walk up or kickback from the workpiece as the saw is restarted.
- d) **Support large panels to minimise the risk of blade pinching and kickback.** Large panels tend to sag under their own weight. Supports must be placed under the panel on both sides, near the line of cut and near the edge of the panel.
- e) **Do not use dull or damaged blades.** Unsharpened or improperly set blades produce narrow kerf causing excessive friction, blade binding and kickback.
- f) **Blade depth and bevel adjusting locking levers must be tight and secure before making the cut.** If blade adjustment shifts while cutting, it may cause binding and kickback.
- g) **Use extra caution when sawing into existing walls or other blind areas.** The protruding blade may cut objects that can cause kickback.

Lower guard function

- a) **Check the lower guard for proper closing before each use. Do not operate the saw if the lower guard does not move freely and close instantly. Never clamp or tie the lower guard into the open position.** If the saw is accidentally dropped, the lower guard may be bent. Raise the lower guard with the retracting handle and make sure it moves freely and does not touch the blade or any other part, in all angles and depths of cut.
- b) **Check the operation of the lower guard spring. If the guard and the spring are not operating properly, they must be serviced before use.** Lower guard may operate sluggishly due to damaged parts, gummy deposits, or a build-up of debris.
- c) **The lower guard may be retracted manually only for special cuts such as „plunge cuts“ and „compound cuts“.** Raise the lower guard by the retracting handle and as soon as the blade enters the material, the lower guard must be released. For all other sawing, the lower guard should operate automatically. NOTE Alternate wording for „retracting handle“ is possible.

d) **Always observe that the lower guard is covering the blade before placing the saw down on bench or floor.** An unprotected, coasting blade will cause the saw to walk backwards, cutting whatever is in its path. Be aware of the time it takes for the blade to stop after switch is released.

Additional Safety and Working Instructions

Wear ear protectors. Exposure to noise can cause hearing loss.

Use protective equipment. Always wear safety glasses when working with the machine. The use of protective clothing is recommended, such as dust mask, protective gloves, sturdy non-slip footwear, helmet and ear defenders.

The dust produced when using this tool may be harmful to health. Do not inhale the dust. Use a dust absorption system and wear a suitable dust protection mask. Remove deposited dust thoroughly, e.g. with a vacuum cleaner.

Do not use saw blades not corresponding to the key data given in these instructions for use.

Do not fix the on/off switch in the „on“ position when using the saw hand-held.

Do not use abrasion disks in this machine!

Remove the battery pack before starting any work on the appliance.

WARNING! To reduce the risk of fire, personal injury, and product damage due to a short circuit, never immerse your tool, battery pack or charger in fluid or al-low a fluid to flow inside them. Corrosive or conductive fluids, such as seawater, certain industrial chemicals, and bleach or bleach containing products, etc., Can cause a short circuit.

Use only System M18 chargers for charging System M18 battery packs. Do not use battery packs from other systems.

Never break open battery packs and chargers and store only in dry rooms. Keep dry at all times.

WORKING INSTRUCTIONS

Adapt the feed speed to avoid overheating the blade tips and to avoid melting plastic materials during cutting.

SPECIFIED CONDITIONS OF USE

This electronic circular saw can cut lengthways and mitre accurately in wood.

ELECTRIC BRAKE

The electric brake engages when the trigger is released, causing the blade to stop and allowing you to proceed with your work. Generally, the saw blade stops within two seconds. However, there may be a delay between the time you release the trigger and when the brake engages. Occasionally the brake may miss completely. If the brake misses frequently, the saw needs servicing by an authorized Milwaukee service facility. You must always wait for the blade to stop completely before removing the saw from the workpiece.

BATTERIES

Battery packs which have not been used for some time should be recharged before use.

Temperatures in excess of 50°C (122°F) reduce the performance of the battery pack. Avoid extended exposure to heat or sunshine (risk of overheating).

The contacts of chargers and battery packs must be kept clean.



For an optimum life-time, the battery packs have to be fully charged, after use.

To obtain the longest possible battery life remove the battery pack from the charger once it is fully charged.

For battery pack storage longer than 30 days: Store the battery pack where the temperature is below 27°C and away from moisture. Store the battery packs in a 30% - 50% charged condition. Every six months of storage, charge the pack as normal.

Do not dispose of used battery packs in the household refuse or by burning them. Milwaukee Distributors offer to retrieve old batteries to protect our environment.

Do not store the battery pack together with metal objects (short circuit risk).

Battery acid may leak from damaged batteries under extreme load or extreme temperatures. In case of contact with battery acid wash it off immediately with soap and water. In case of eye contact rinse thoroughly for at least 10 minutes and immediately seek medical attention.

No metal parts must be allowed to enter the battery section of the charger (short circuit risk).



XII

BATTERY PACK PROTECTION

In extremely high torque, binding, stalling and short circuit situations that cause high current draw, the tool will stop for about 2 seconds and then the tool will turn OFF. To reset, release the trigger. Under extreme circumstances, the internal temperature of the battery could become too high. If this happens, the battery will shut down. To reset, release the trigger. Under extreme circumstances, the internal temperature of the battery could become too high. If this happens, the battery will shut down. Place the battery on the charger to charge and reset it.

TRANSPORTING LITHIUM BATTERIES

Lithium-ion batteries are subject to the Dangerous Goods Legislation requirements.

Transportation of those batteries has to be done in accordance with local, national and international provisions and regulations.

The user can transport the batteries by road without further requirements.

Commercial transport of Lithium-Ion batteries by third parties is subject to Dangerous Goods regulations. Transport preparation and transport are exclusively to be carried out by appropriately trained persons and the process has to be accompanied by corresponding experts.

When transporting batteries:

Ensure that battery contact terminals are protected and insulated to prevent short circuit. Ensure that battery pack is secured against movement within packaging. Do not transport batteries that are cracked or leak. Check with forwarding company for further advice

MAINTENANCE

Be sure to disconnect the tool from the power supply before attaching or removing the saw blade.

Clean tool and guarding system with dry cloth.

Certain cleaning agents and solvents are harmful to plastics and other insulated parts.

Keep the apparatus handle clean, dry and free of spilt oil or grease. Check the function of guards.

Regular maintenance and cleaning provide for a long service life and safe handling.

The ventilation slots of the machine must be kept clear at all times.

Remove dust regularly. Remove the sawdust which has accumulated inside the saw in order to avoid the risk of fire.

Use only Milwaukee accessories and Milwaukee spare parts. Should components need to be replaced which have not been described, please contact one of our Milwaukee service agents (see our list of guarantee/service addresses).

If needed, an exploded view of the tool can be ordered. Please state the Article No. as well as the machine type printed on the label and order the drawing at your local service agents or directly at: Techtronic Industries GmbH, Max-Eyth-Straße 10, 71364 Winnenden, Germany.

EC-DECLARATION OF CONFORMITY

We declare under our sole responsibility that the product described under "Technical Data" fulfills all the relevant provisions of the directives

2011/65/EU (RoHS)

2006/42/EC

2014/30/EU

and the following harmonized standards have been used.

EN 60745-1:2009 + A11:2010

EN 60745-2-5:2010

EN 55014-1:2017:A11 2020

EN 55014-2:2015

EN IEC 63000:2018



Winnenden, 2020-11-10

Alexander Krug / Managing Director

Authorized to compile the technical file

Techtronic Industries GmbH

Max-Eyth-Straße 10, 71364 Winnenden, Germany

GB-DECLARATION OF CONFORMITY

We declare as the manufacturer under our sole responsibility that the product described under „Technical Data“ fulfills all the relevant provisions of the following Regulations

S.I. 2012/3032 (as amended), S.I. 2008/1597 (as amended),
S.I. 2016/1091 (as amended) and that the following designated standards have been used:

BS EN 60745-1:2009+A11:2010

BS EN 60745-2-5:2010

BS EN 55014-1:2017+A11:2020

BS EN 55014-2:2015

BS EN IEC 63000:2018

Winnenden, 2020-11-10



Alexander Krug / Managing Director
Authorized to compile the technical file

Techtronic Industries GmbH
Max-Eyth-Straße 10, 71364 Winnenden, Germany



SYMBOLS



CAUTION! WARNING! DANGER!



Please read the instructions carefully before starting the machine.



Always wear goggles when using the machine.



Remove the battery pack before starting any work on the appliance.



Accessory - Not included in standard equipment, available as an accessory.



Do not dispose electric tools, batteries/rechargeable batteries together with household waste material. Electric tools and batteries that have reached the end of their life must be collected separately and returned to an environmentally compatible recycling facility. Check with your local authority or retailer for recycling advice and collection point.



European Conformity Mark



British Conformity Mark



Ukraine Conformity Mark



EurAsian Conformity Mark

Copyright 2020
Techtronic Industries GmbH
Max-Eyth-Straße 10
71364 Winnenden
Germany
+49 (0) 7195-12-0
www.milwaukeeetool.eu

Techtronic Industries (UK) Ltd
Fieldhouse Lane
Marlow Bucks SL7 1HZ
UK



**EAC UK
CA**

(11.20)

4100 4252 22