



Nothing but **HEAVY DUTY.**



# **M18 FLAG180XPDB**

# **M18 FLAG230XPDB**

---

Original instructions



3



4



7



17



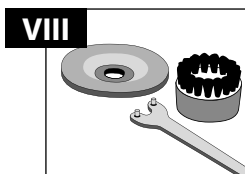
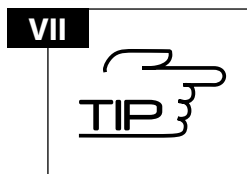
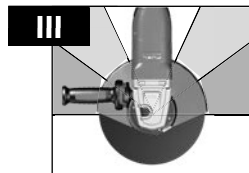

**X** Technical Data, Safety Instructions, Specified Conditions of Use, Declaration of Conformity, Batteries, Maintenance, Symbols  
**Please read and save these instructions!**



**AVS**

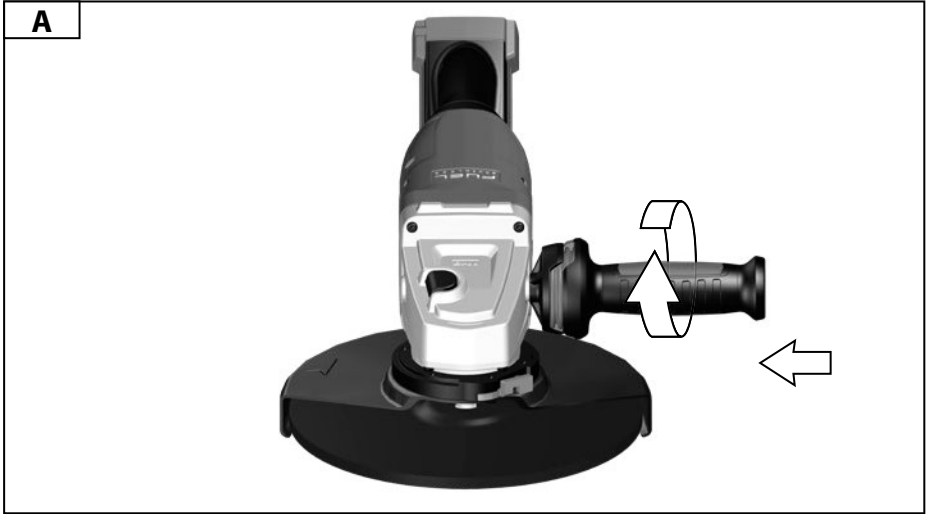

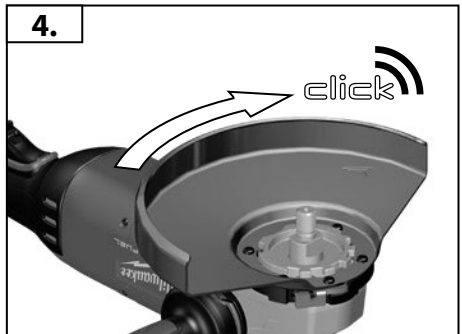
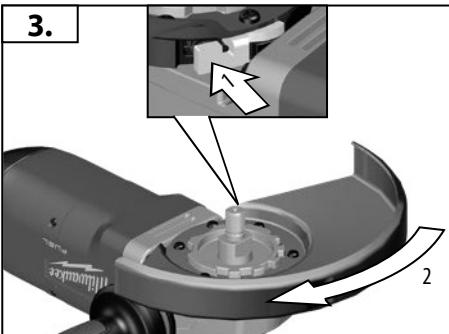
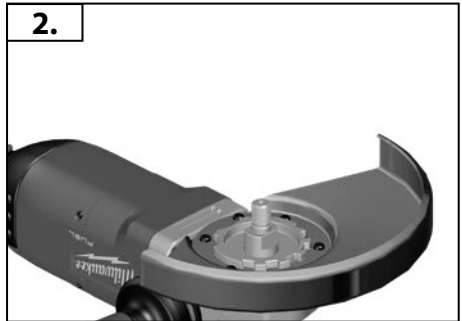
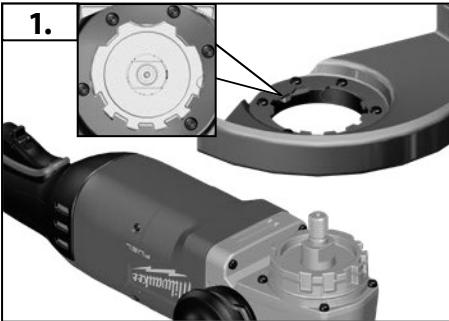
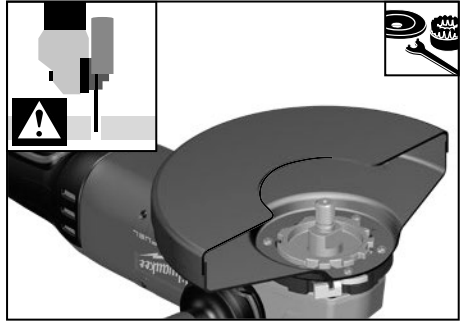
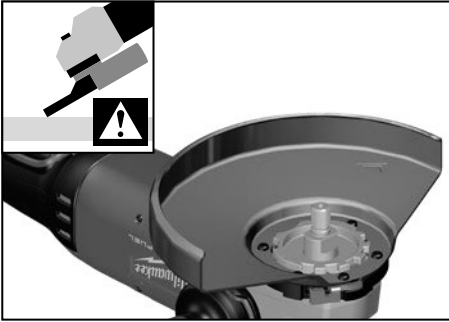

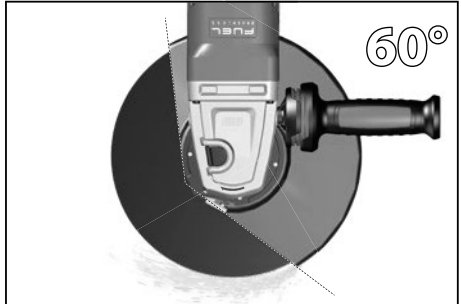
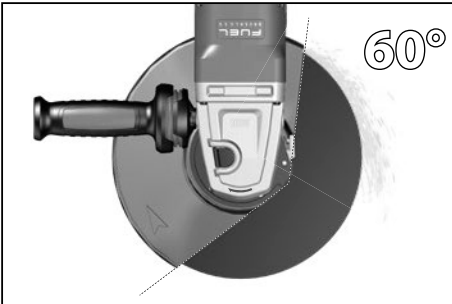
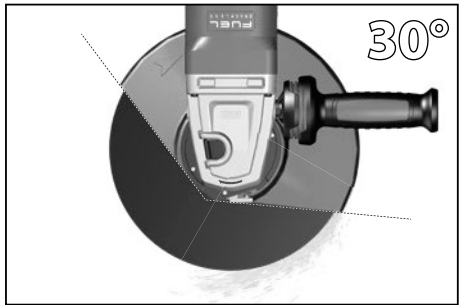
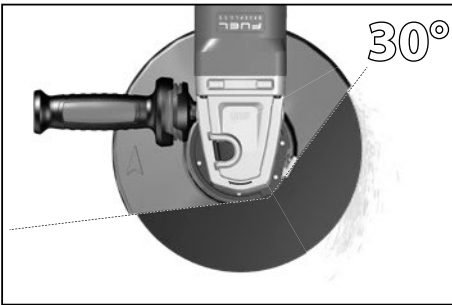
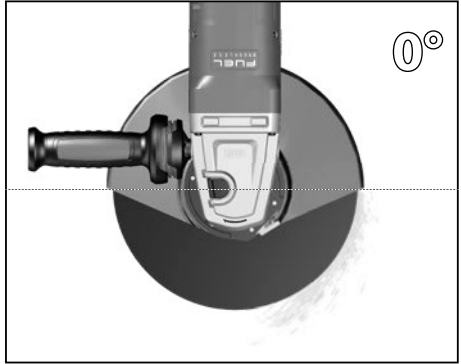
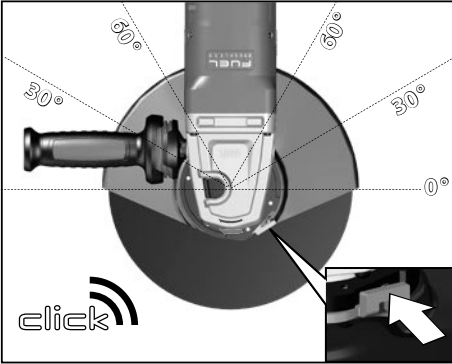
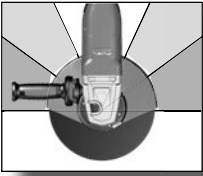

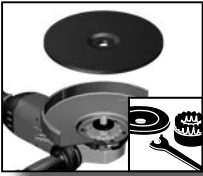

**FIX  
TEC**

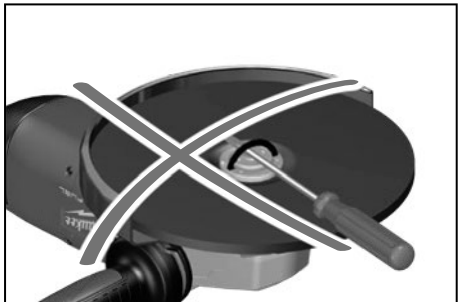
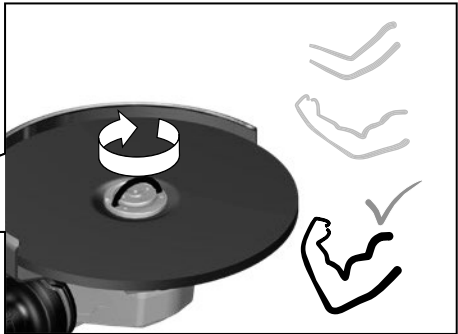
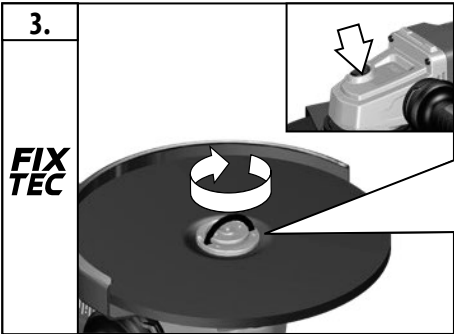
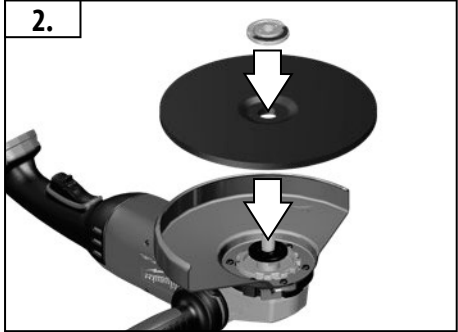
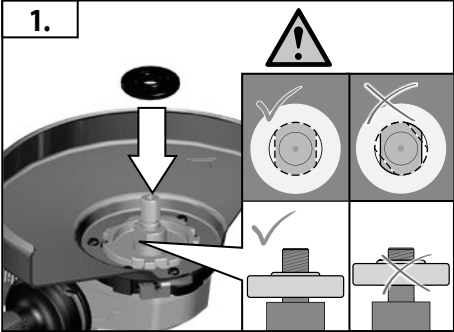

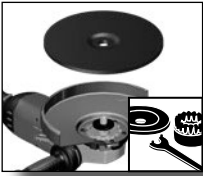

**FIX  
TEC**

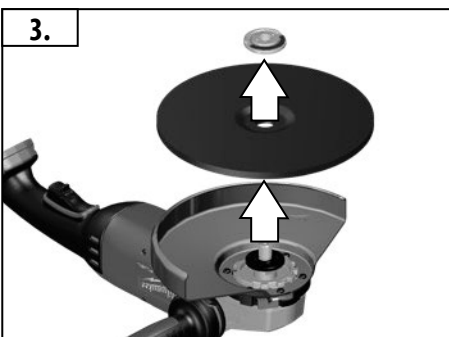
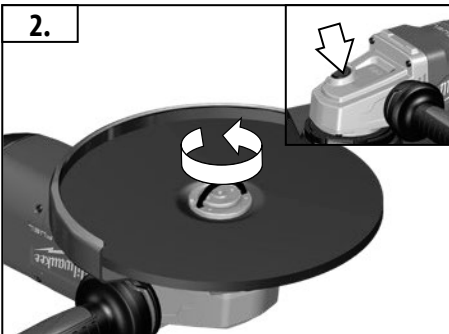
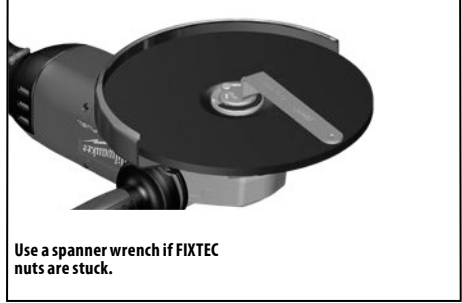
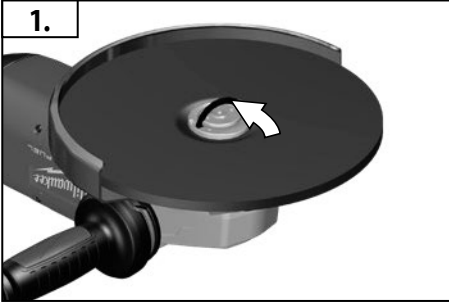
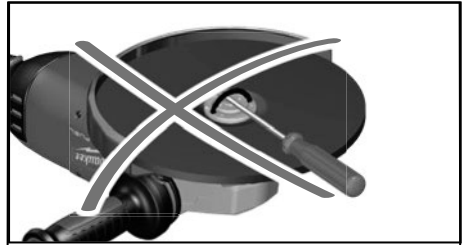



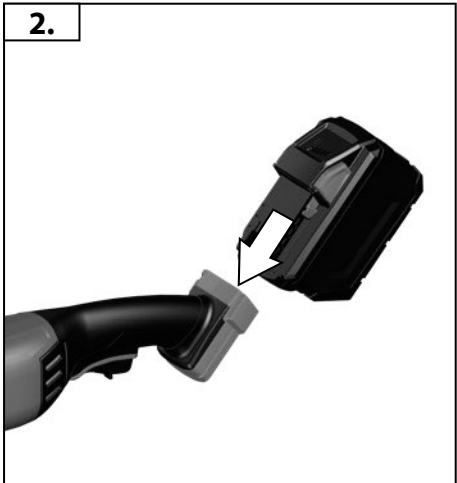
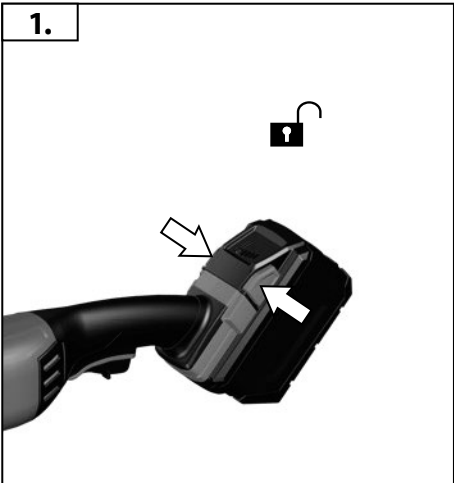
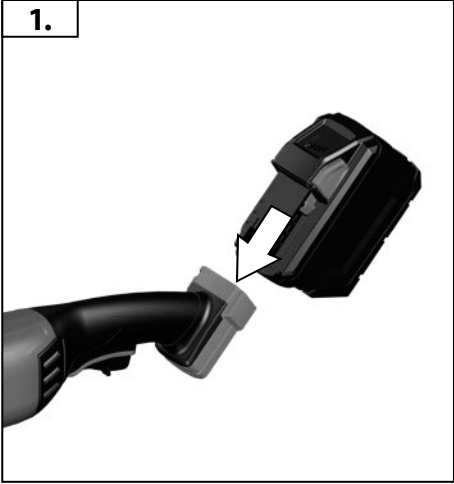

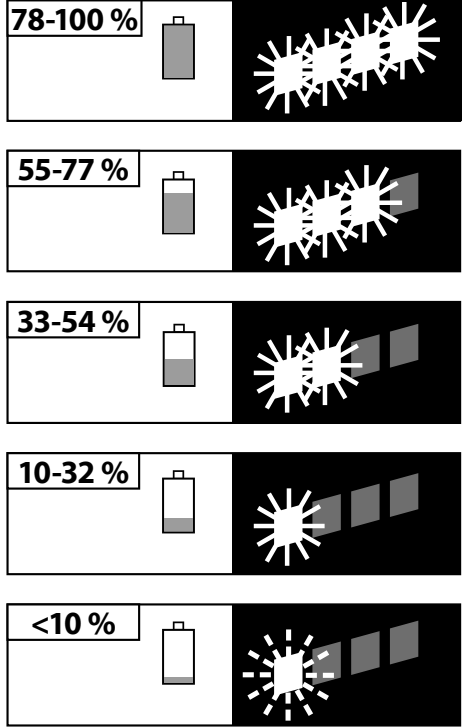
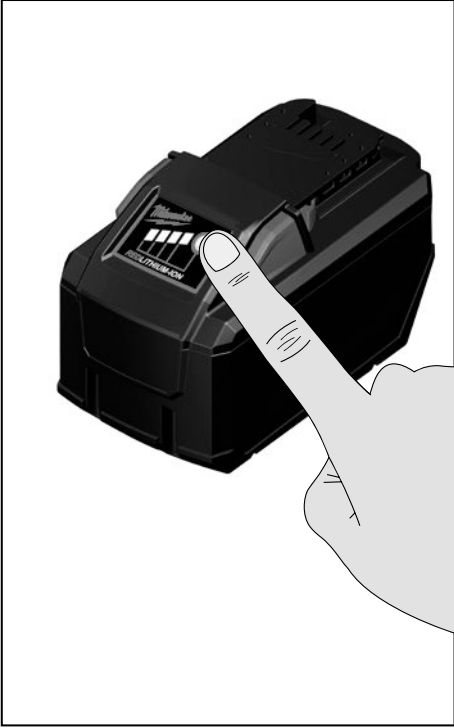



**START  
STOP**

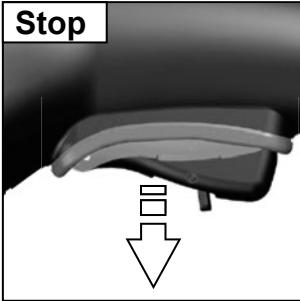
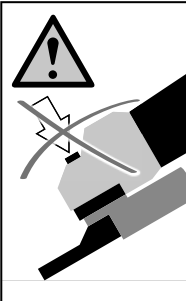
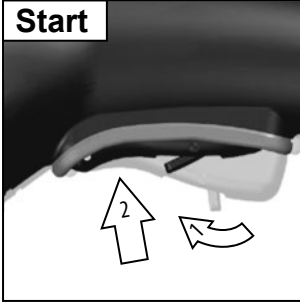

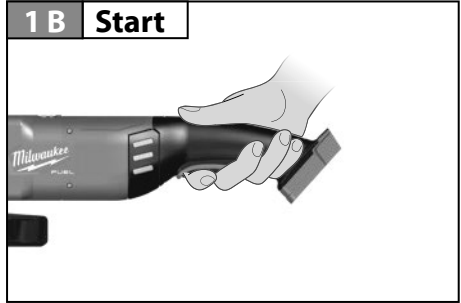
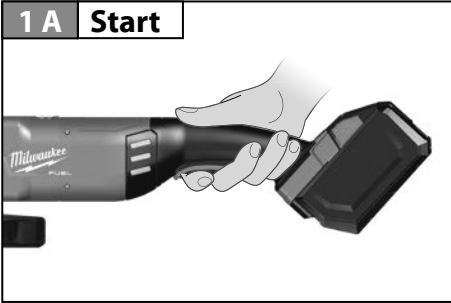

**START**  
**STOP**

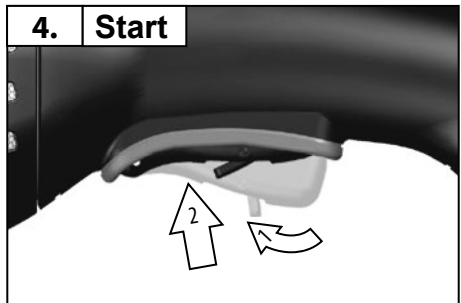
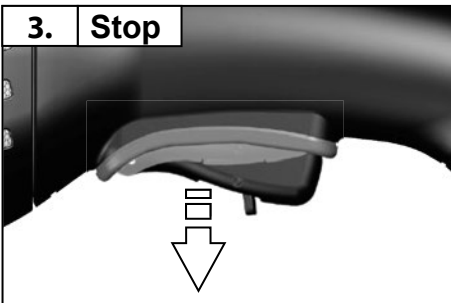
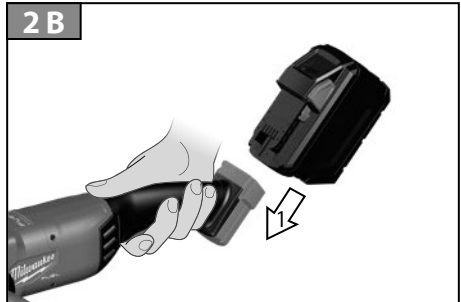
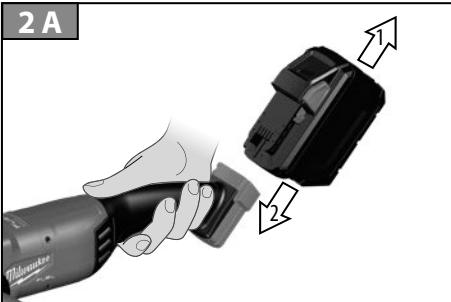



**START  
STOP**

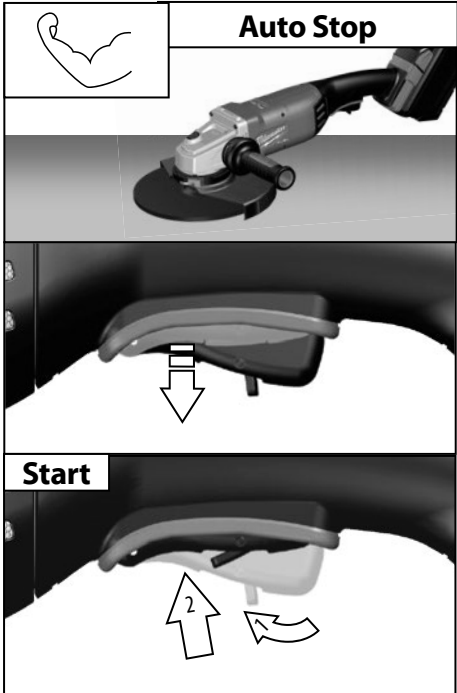
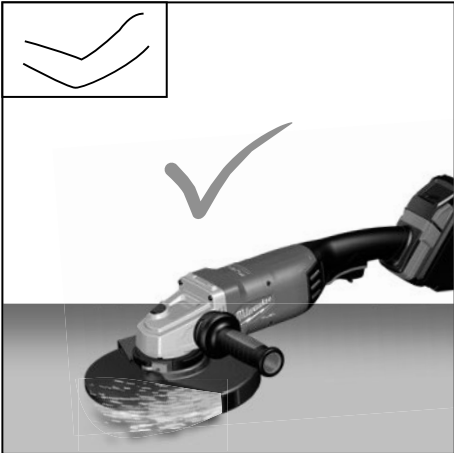

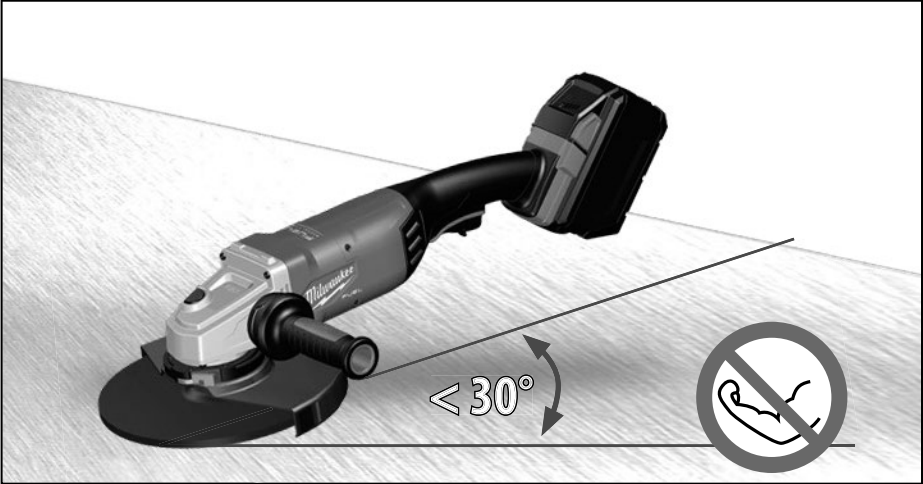
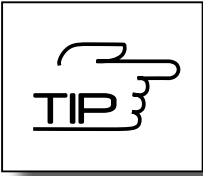

VII

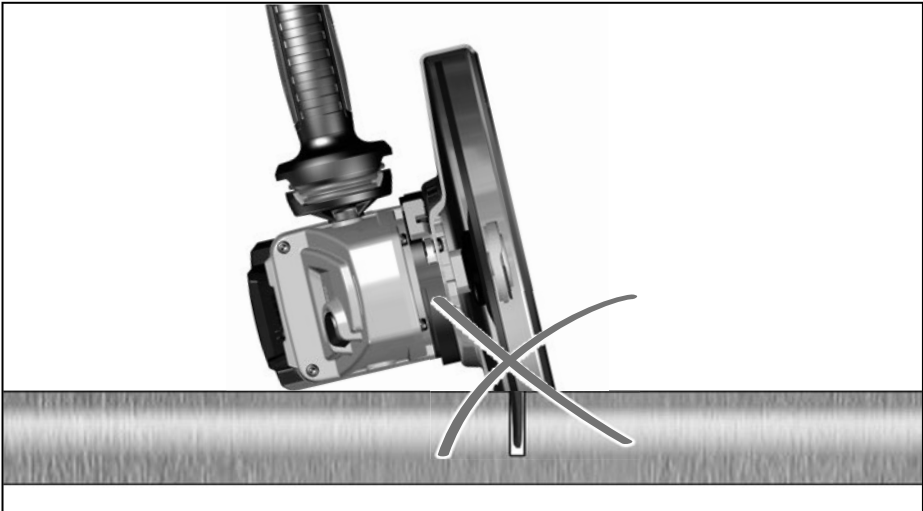

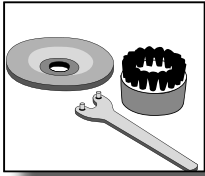

Accessory

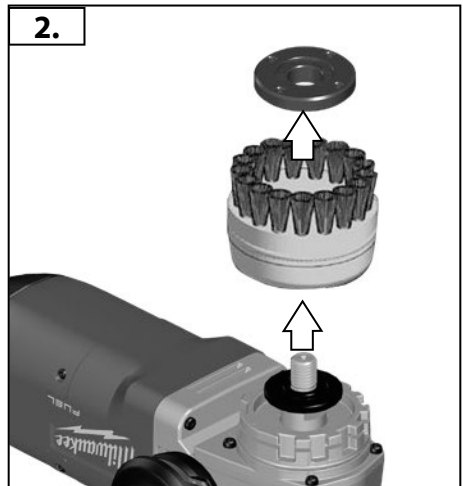
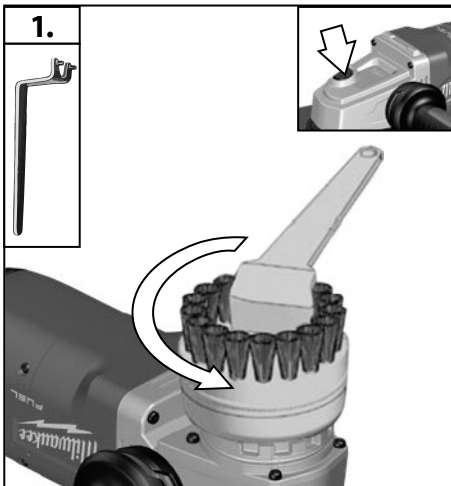
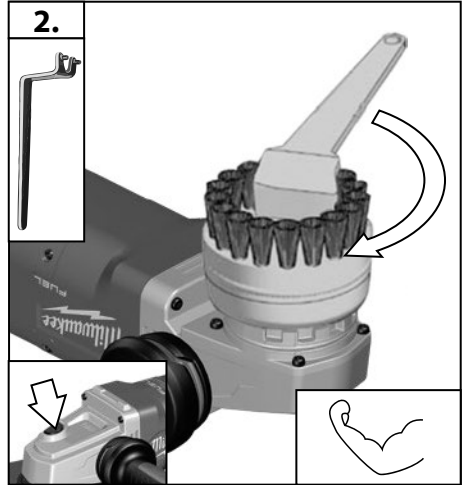
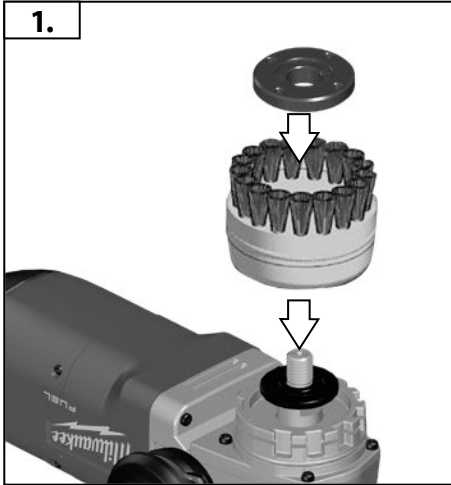
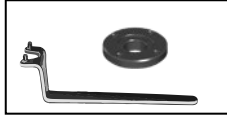

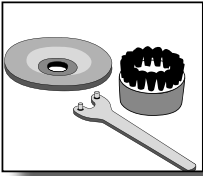

Accessory

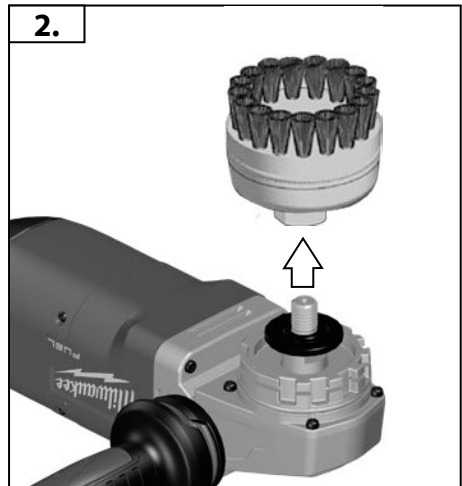
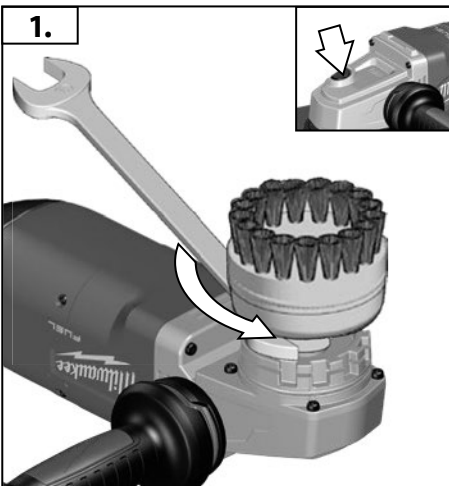
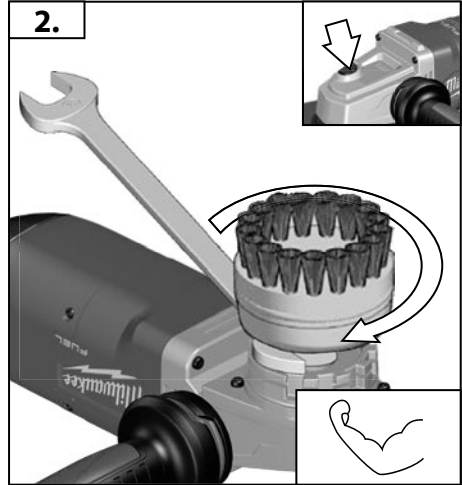
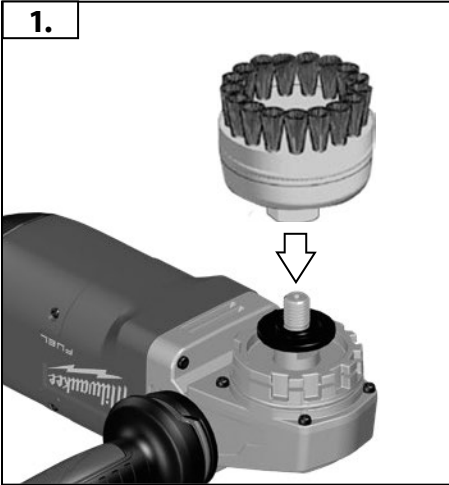



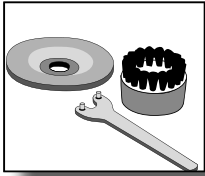



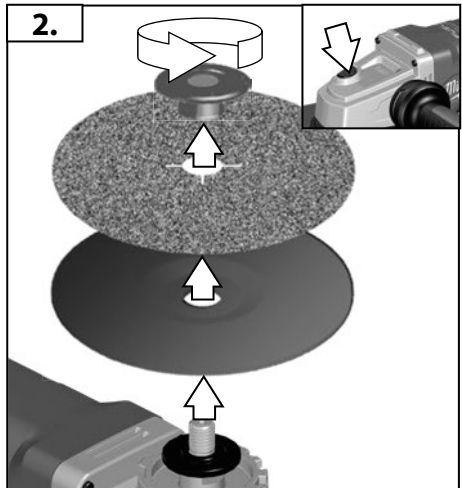
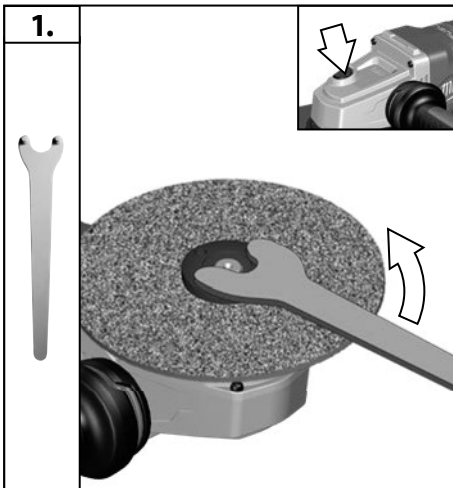
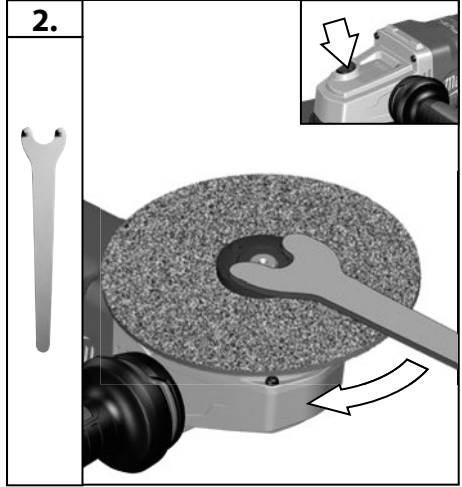
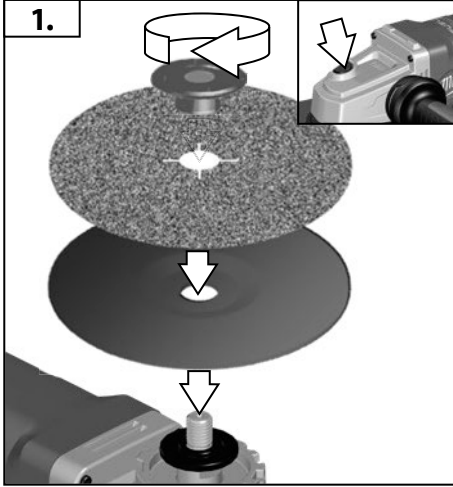
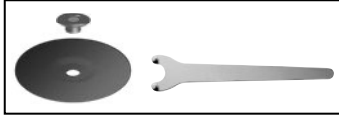

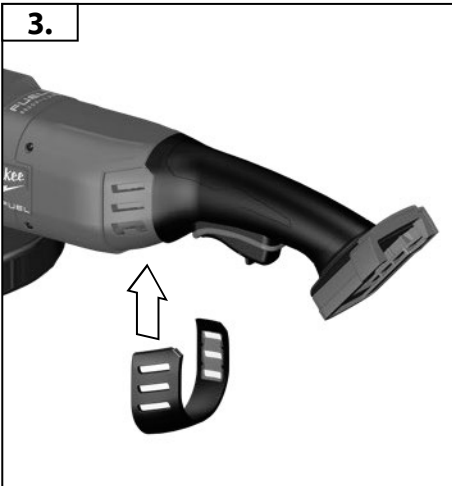
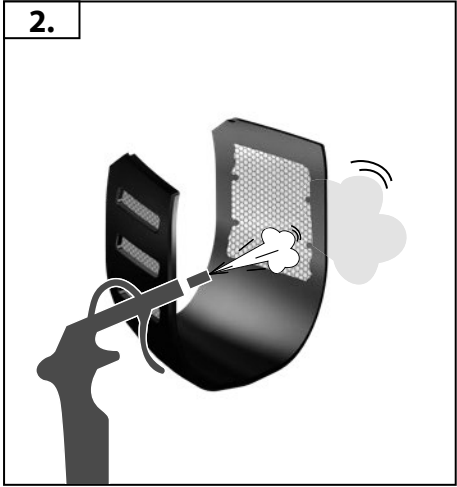
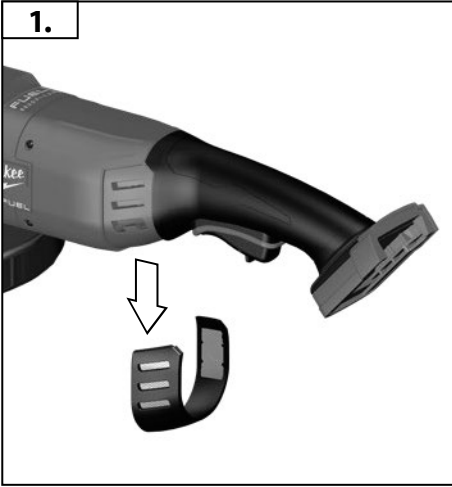
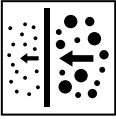
Accessory





TECHNICAL DATA Cordless Angle Grinder	M18 FLAG180XPDB	M18 FLAG230XPDB
Production code	4679 00 02 ... 000001-999999	4678 90 02 ... 000001-999999
Battery voltage	18 V	18 V
Rated speed	6600 min <sup>-1</sup>	6600 min <sup>-1</sup>
D= Grinding disc diameter max. d= Grinding disc hole diameter	180 mm 22,2 mm	230 mm 22,2 mm
 b= Cutting disc thickness min. / max.	1,9 / 3 mm	1,9 / 3 mm
 b= Grinding disc thickness max.	8 mm	8 mm
 D= Grinding surface diameter max.	180 mm	230 mm
 D= Wiring brush diameter max.	100 mm	100 mm
Thread of work spindle	M 14	M 14
Weight according EPTA-Procedure 01/2014 (Li-Ion 12,0Ah)	5,1 kg	5,3 kg
Recommended Ambient Operating Temperature	-18°C ... +50°C	-18°C ... +50°C
Recommended battery types	M18HB12	M18HB12
Recommended charger	M12-18...	M12-18...
<b>Noise information</b>		
Measured values determined according to EN 60745. Typically, the A-weighted noise levels of the tool are:		
Sound pressure level (Uncertainty K=3dB(A))	79,7 dB(A)	79,7 dB(A)
Sound power level (Uncertainty K=3dB(A))	90,6 dB(A)	90,6 dB(A)
<b>Wear ear protectors!</b>		
<b>Vibration information</b>		
Vibration total values (triaxial vector sum) determined according to EN 60745		
Surface grinding (Li-Ion 12,0Ah): Vibration emission value $a_{h,AG}$	9,5 m/s <sup>2</sup>	10,2 m/s <sup>2</sup>
Uncertainty K=	1,5 m/s <sup>2</sup>	1,5 m/s <sup>2</sup>
disc sanding (Li-Ion 12,0Ah): Vibration emission value $a_{h,DS}$	1,4 m/s <sup>2</sup>	1,6 m/s <sup>2</sup>
Uncertainty K=	1,5 m/s <sup>2</sup>	1,5 m/s <sup>2</sup>

For other applications, e.g. Abrasive Cutting-Off Operations or Wire Brushing other vibration values could occur.

### WARNING!

The vibration emission level given in this information sheet has been measured in accordance with a standardised test given in EN 60745 and may be used to compare one tool with another. It may be used for a preliminary assessment of exposure.

The declared vibration emission level represents the main applications of the tool. However if the tool is used for different applications, with different accessories or poorly maintained, the vibration emission may differ. This may significantly increase the exposure level over the total working period.

An estimation of the level of exposure to vibration should also take into account the times when the tool is switched off or when it is running but not actually doing the job. This may significantly reduce the exposure level over the total working period.

Identify additional safety measures to protect the operator from the effects of vibration such as: maintain the tool and the accessories, keep the hands warm, organisation of work patterns.

## **⚠ WARNING!**

**Read all safety warnings and all instructions.** Failure to follow the warnings and instructions may result in electric shock, fire and/or serious injury.

**Save all warnings and instructions for future reference.**

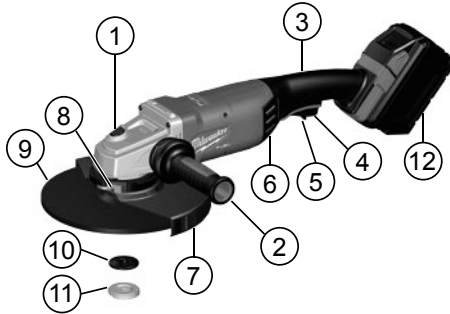

### Device description

- |   |                             |
|---|-----------------------------|
| ① Spindle lock                              | ⑥ Dust screen               |
| ② Side handle<br>Insulated gripping surface | ⑦ Grinding or Cutting Guard |
| ③ Handle Insulated gripping surface         | ⑧ Guard lock lever          |
| ④ Trigger                                   | ⑨ Accessory                 |
| ⑤ Switch lock-off                           | ⑩ Flange                    |
|   | ⑪ FIXTEC nut                |
|   | ⑫ Battery                   |

## **⚠ ANGLE GRINDER SAFETY WARNINGS**

### Safety Warnings Common for Grinding, Sanding, Wire Brushing or Abrasive Cutting-Off Operations:

**a) This power tool is intended to function as a grinder, sander, wire brush or cut-off tool. Read all safety warnings, instructions, illustrations and specifications provided with this power tool.** Failure to follow all instructions listed below may result in electric shock, fire and/or serious injury.

**b) Operations such as polishing are not recommended to be performed with this power tool.** Operations for which the power tool was not designed may create a hazard and cause personal injury.

**c) Do not use accessories which are not specifically designed and recommended by the tool manufacturer.** Just because the accessory can be attached to your power tool, it does not assure safe operation.

**d) The rated speed of the accessory must be at least equal to the maximum speed marked on the power tool.** Accessories running faster than their rated speed can break and fly apart.

**e) The outside diameter and the thickness of your accessory must be within the capacity rating of your power tool.** Incorrectly sized accessories cannot be adequately guarded or controlled.

**f) Threaded mounting of accessories must match the grinder spindle thread. For accessories mounted by flanges, the arbour hole of the accessory must fit the locating diameter of the flange.** Accessories that do not match the mounting hard-

ware of the power tool will run out of balance, vibrate excessively and may cause loss of control.

**g) Do not use a damaged accessory. Before each use inspect the accessory such as abrasive wheels for chips and cracks, backing pad for cracks, tear or excess wear, wire brush for loose or cracked wires. If power tool or accessory is dropped, inspect for damage or install an undamaged accessory. After inspecting and installing an accessory, position yourself and bystanders away from the plane of the rotating accessory and run the power tool at maximum no-load speed for one minute.** Damaged accessories will normally break apart during this test time.

**h) Wear personal protective equipment. Depending on application, use face shield, safety goggles or safety glasses. As appropriate, wear dust mask, hearing protectors, gloves and workshop apron capable of stopping small abrasive or workpiece fragments.** The eye protection must be capable of stopping flying debris generated by various operations. The dust mask or respirator must be capable of filtering particles generated by your operation. Prolonged exposure to high intensity noise may cause hearing loss.

**i) Keep bystanders a safe distance away from work area. Anyone entering the work area must wear personal protective equipment.** Fragments of workpiece or of a broken accessory may fly away and cause injury beyond immediate area of operation.

**j) Hold the power tool by insulated gripping surfaces only, when performing an operation where the cutting accessory may contact hidden wiring.** Cutting accessory contacting a "live" wire may make exposed metal parts of the power tool "live" and could give the operator an electric shock.

**k) Never lay the power tool down until the accessory has come to a complete stop.** The spinning accessory may grab the surface and pull the power tool out of your control.

**l) Do not run the power tool while carrying it at your side.** Accidental contact with the spinning accessory could snag your clothing, pulling the accessory into your body.

**m) Regularly clean the power tool's air vents.** The motor's fan will draw the dust inside the housing and excessive accumulation of powdered metal may cause electrical hazards.

**n) Do not operate the power tool near flammable materials.** Sparks could ignite these materials.

**o) Do not use accessories that require liquid coolants.** Using water or other liquid coolants may result in electrocution or shock.

### Kickback and Related Warnings

Kickback is a sudden reaction to a pinched or snagged rotating wheel, backing pad, brush or any other accessory. Pinching or snagging causes rapid stalling of the rotating accessory which in turn causes the uncontrolled power tool to be forced in the direction opposite of the accessory's rotation at the point of the binding.

For example, if an abrasive wheel is snagged or pinched by the workpiece, the edge of the wheel that is entering into the pinch point can dig into the surface of the material causing the wheel to climb out or kick out. The wheel may either jump toward or away from the operator, depending on direction of the wheel's movement at the point of pinching. Abrasive wheels may also break under these conditions.

Kickback is the result of power tool misuse and/or incorrect operating procedures or conditions and can be avoided by taking proper precautions as given below.

**a) Maintain a firm grip on the power tool and position your body and arm to allow you to resist kickback forces. Always**



use auxiliary handle, if provided, for maximum control over kickback or torque reaction during start-up. The operator can control torque reactions or kickback forces, if proper precautions are taken.

**b) Never place your hand near the rotating accessory.** Accessory may kickback over your hand.

**c) Do not position your body in the area where power tool will move if kickback occurs.** Kickback will propel the tool in direction opposite to the wheel's movement at the point of snagging.

**d) Use special care when working corners, sharp edges etc. Avoid bouncing and snagging the accessory.** Corners, sharp edges or bouncing have a tendency to snag the rotating accessory and cause loss of control or kickback.

**e) Do not attach a saw chain woodcarving blade or toothed saw blade.** Such blades create frequent kickback and loss of control.

#### Safety Warnings Specific for Grinding and Abrasive Cutting-Off Operations:

**a) Use only wheel types that are recommended for your power tool and the specific guard designed for the selected wheel.** Wheels for which the power tool was not designed cannot be adequately guarded and are unsafe.

**b) The grinding surface of the centre depressed wheels must be mounted below the plane of the guard lip.** An improperly mounted wheel that projects through the plane of the guard lip cannot be adequately protected.

**c) The guard must be securely attached to the power tool and positioned for maximum safety, so the least amount of wheel is exposed towards the operator.** The guard helps to protect the operator from broken wheel fragments, accidental contact with wheel and sparks that could ignite clothing.

**d) Wheels must be used only for recommended applications. For example: do not grind with the side of cut-off wheel.** Abrasive cut-off wheels are intended for peripheral grinding, side forces applied to these wheels may cause them to shatter.

**e) Always use undamaged wheel flanges that are of correct size and shape for your selected wheel.** Proper wheel flanges support the wheel thus reducing the possibility of wheel breakage. Flanges for cut-off wheels may be different from grinding wheel flanges.

**f) Do not use worn down wheels from larger power tools.** Wheel intended for larger power tool is not suitable for the higher speed of a smaller tool and may burst.

#### Additional Safety Warnings Specific for Abrasive Cutting-Off Operations:

**a) Do not "jam" the cut-off wheel or apply excessive pressure. Do not attempt to make an excessive depth of cut.** Overstressing the wheel increases the loading and susceptibility to twisting or binding of the wheel in the cut and the possibility of kickback or wheel breakage.

**b) Do not position your body in line with and behind the rotating wheel.** When the wheel, at the point of operation, is moving away from your body, the possible kickback may propel the spinning wheel and the power tool directly at you.

**c) When wheel is binding or when interrupting a cut for any reason, switch off the power tool and hold the power tool motionless until the wheel comes to a complete stop. Never attempt to remove the cut-off wheel from the cut while the wheel is in motion otherwise kickback may occur.** Investigate and take corrective action to eliminate the cause of wheel binding.

**d) Do not restart the cutting operation in the workpiece. Let the wheel reach full speed and carefully re-enter the cut.** The wheel may bind, walk up or kickback if the power tool is restarted in the workpiece.

**e) Support panels or any oversized workpiece to minimize the risk of wheel pinching and kickback.** Large workpieces tend to sag under their own weight. Supports must be placed under the workpiece near the line of cut and near the edge of the workpiece on both sides of the wheel.

**f) Use extra caution when making a "pocket cut" into existing walls or other blind areas.** The protruding wheel may cut gas or water pipes, electrical wiring or objects that can cause kickback.

#### Safety Warnings Specific for Sanding Operations:

**a) Do not use excessively oversized sanding disc paper. Follow manufacturers recommendations, when selecting sanding paper.** Larger sanding paper extending beyond the sanding pad presents a laceration hazard and may cause snagging, tearing of the disc or kickback.

#### Safety Warnings Specific for Wire Brushing Operations:

**a) Be aware that wire bristles are thrown by the brush even during ordinary operation. Do not overstress the wires by applying excessive load to the brush.** The wire bristles can easily penetrate light clothing and/or skin.

**b) If the use of a guard is recommended for wire brushing, do not allow any interference of the wire wheel or brush with the guard.** Wire wheel or brush may expand in diameter due to work load and centrifugal forces.

#### Additional Safety and Working Instructions

Always check the spindle lock button in fully released before switching on the tool! After using the spindle lock to tighten / loosen the abrasive disc, it is possible that the button may stick in the lock position. Whilst it may cause the tool or battery protection to operate and remove power to the tool. Turn off the switch, remove the battery then carefully rock the disc back and forth to release the spindle lock button.

When grinding metal, flying sparks are produced. Take care that no persons are endangered. Because of the danger of fire, no combustible materials should be located in the vicinity (spark light zone). Do not use dust extraction.

Avoid flying sparks and sanding dust hit your body.

Never reach into the danger area of the machine when it is running.

Chips and splinters must not be removed while the machine is running.

Immediately switch off the machine in case of considerable vibrations or if other malfunctions occur. Check the machine in order to find out the cause.

Under extreme conditions (e.g. smooth-grinding metals with the arbour and vulcanized fibre grinding wheel), significant contamination can build up on the inside of the angle grinder.

Do not let any metal parts enter the airing slots - danger of short circuit!

**WARNING!** Danger of burns! The wheel and workpiece will become hot during use. Wear gloves when changing discs or touching workpiece. Keep hands away from the grinding area at all times.

**WARNING!** To reduce the risk of fire, personal injury, and product damage due to a short circuit, never immerse your tool, battery pack or charger in fluid or allow a fluid to flow inside them. Corrosive or conductive fluids, such as seawater, certain industrial



chemicals, and bleach containing products, etc., Can cause a short circuit.

Never break open battery packs and chargers and store only in dry rooms. Keep dry at all times.

Use only System M18 chargers for charging System M18 battery packs. Do not use battery packs from other systems.

#### SPECIFIED CONDITIONS OF USE

The angle grinder is intended for grinding and cutting metal, stone and ceramic materials as well as sanding and wire brushing.

Use the cutting guard from the accessories range for cutting application.

Please refer to the instructions supplied by the accessory manufacturer.

The machine is suitable only for working without water.

Only appropriate grinding or cutting discs and related guards (grinding guard or cutting guard) as described in the product specification section of this manual should be fitted to the angle grinder. The angle grinder is designed for handheld use; it is not to be mounted onto a fixture or workbench.

Do not use the product in any way other than those stated for intended use.

#### WORKING INSTRUCTIONS

For accessories intended to be fitted with threaded hole wheel, ensure that the thread in the wheel is long enough to accept the spindle length.

Always use and store the cutting and grinding wheels according to the manufacturer's instructions.

Always use the correct guard for cutting and grinding.

The grinding surface of the centre depressed wheels must be mounted min. 2 mm below the plane of the guard lip.

The adjusting nut must be tightened before starting to work with the machine.

Always use the auxiliary handle.

The workpiece must be fixed if it is not heavy enough to be steady. Never move the workpiece towards the rotating wheel by hand.

The flange nut must be securely tightened before the machine is started. If the tool is not securely tightened with the flange nut, it is possible that the tool will lose the required clamping force when it is decelerated.

#### BATTERIES

Temperatures in excess of 50°C (122°F) reduce the performance of the battery pack. Avoid extended exposure to heat or sunshine (risk of overheating).

The contacts of chargers and battery packs must be kept clean.

For an optimum life-time, the battery packs have to be fully charged, after use. Battery packs which have not been used for some time should be recharged before use.

To obtain the longest possible battery life remove the battery pack from the charger once it is fully charged.

For battery pack storage longer than 30 days: Store the battery pack where the temperature is below 27°C and away from moisture. Store the battery packs in a 30% - 50% charged condition. Every six months of storage, charge the pack as normal.

Do not dispose of used battery packs in the household refuse or by burning them. Milwaukee Distributors offer to retrieve old batteries to protect our environment.

Do not store the battery pack together with metal objects (short circuit risk).

#### BATTERY PACK PROTECTION

In extremely high torque, binding, stalling and short circuit situations that cause high current draw, the tool will stop for about 2 seconds and then the tool will turn OFF.

To reset, release the trigger.

Under extreme circumstances, the internal temperature of the battery pack could raise too much. If this happens, the fuel gauge will flash until the battery pack cooled down. After the lights go off, the work may continue. Place the battery on the charger to charge and reset it.

#### TRANSPORTING LITHIUM BATTERIES

Lithium-ion batteries are subject to the Dangerous Goods Legislation requirements.

Transportation of those batteries has to be done in accordance with local, national and international provisions and regulations.

The user can transport the batteries by road without further requirements.

Commercial transport of Lithium-Ion batteries by third parties is subject to Dangerous Goods regulations. Transport preparation and transport are exclusively to be carried out by appropriately trained persons and the process has to be accompanied by corresponding experts.

When transporting batteries:

Ensure that battery contact terminals are protected and insulated to prevent short circuit. Ensure that battery pack is secured against movement within packaging. Do not transport batteries that are cracked or leak. Check with forwarding company for further advice

#### RESTART PROTECTION

The power tool is supplied with a restart protection. This prevents the switched-on power tool from starting by itself when the power tool is connected to the power source and from restarting after a failure of the power supply. If the cutting wheel is outside of the workpiece switch off the power tool and then switch it back on again in order to continue to work. If the cutting wheel is inside of the workpiece wait until the wheel comes to a complete stop, disconnect the plug from the power source or remove the battery pack, remove the wheel from the cut, switch off the power tool, connect the power tool to the power source and then switch the power tool back on again in order to continue to work.

#### SOFT START

Electronic soft start for save use prevents jerky run-up of the machine.

#### MAINTENANCE

Remove the battery pack before starting any work on the appliance.

The ventilation slots of the machine must be kept clear at all times.

Use only Milwaukee accessories and Milwaukee spare parts. Should components need to be replaced which have not been described, please contact one of our Milwaukee service agents (see our list of guarantee/service addresses).

If needed, an exploded view of the tool can be ordered. Please state the Article No. as well as the machine type printed on the label and order the drawing at your local service agents or directly at: Techtronic Industries GmbH, Max-Eyth-Straße 10, 71364 Winnenden, Germany.



## EC-DECLARATION OF CONFORMITY

We declare under our sole responsibility that the product described under "Technical Data" fulfills all the relevant provisions of the directives

2011/65/EU (RoHS)

2006/42/EC

2014/30/EU

and the following harmonized standards have been used.

EN 60745-1:2009 + A11:2010

EN 60745-2-3:2011+A2:2013

EN 55014-1:2017+A11:2020

EN 55014-2:2015

EN IEC 63000:2018



Winnenden, 2020-11-11

Alexander Krug / Managing Director

Authorized to compile the technical file

Techtronic Industries GmbH

Max-Eyth-Straße 10, 71364 Winnenden, Germany

## GB-DECLARATION OF CONFORMITY

We declare as the manufacturer under our sole responsibility that the product described under "Technical Data" fulfills all the relevant provisions of the following Regulations

S.I. 2012/3032 (as amended), S.I. 2008/1597 (as amended),

S.I. 2016/1091 (as amended) and that the following designated

standards have been used:

BS EN 60745-1:2009 + A11:2010

BS EN 60745-2-3:2011+A13:2015

BS EN 55014-1:2017+A11:2020

BS EN 55014-2:2015

BS EN IEC 63000:2018

Winnenden, 2020-11-11

Alexander Krug / Managing Director

Authorized to compile the technical file

Techtronic Industries GmbH

Max-Eyth-Straße 10, 71364 Winnenden, Germany

## SYMBOLS



CAUTION! WARNING! DANGER!



Please read the instructions carefully before starting the machine.



Always wear goggles when using the machine.



Wear gloves!



Remove the battery pack before starting any work on the appliance.



ANTI Vibration System



Do not use force.



Only for cutting work.



Only for grinding.



Accessory - Not included in standard equipment, available as an accessory.



Do not dispose electric tools, batteries/rechargeable batteries together with household waste material. Electric tools and batteries that have reached the end of their life must be collected separately and returned to an environmentally compatible recycling facility. Check with your local authority or retailer for recycling advice and collection point.

**n**

Rated speed

**V**

Voltage



Direct Current



European Conformity Mark



British Conformity Mark



Ukraine Conformity Mark

001



EurAsian Conformity Mark

Copyright 2020  
Techtronic Industries GmbH  
Max-Eyth-Straße 10  
71364 Winnenden  
Germany  
+49 (0) 7195-12-0  
[www.milwaukeeetool.eu](http://www.milwaukeeetool.eu)

Techtronic Industries (UK) Ltd  
Fieldhouse Lane  
Marlow Bucks SL7 1HZ  
UK



**EAC UK  
CA**

(11.20)

**4100 4256 02**