

# RYOBI®

R4SDP

ORIGINAL INSTRUCTIONS

## 4V screwdriver



## **Important!**

It is essential that you read the instructions in this manual before assembling, operating, and maintaining the product.

Subject to technical modification.

This appliance is not intended to be used or cleaned by persons with reduced physical, sensory or mental capabilities, or lack of experience or knowledge, unless they have been given instructions concerning the safe use of the appliance by a person legally responsible for their safety. They should be supervised whilst using the appliance. Children shall not use, clean or play with this appliance, which when not in use should be secured out of their reach.

Safety, performance, and dependability have been given top priority in the design of your screwdriver.

### INTENDED USE

The screwdriver is intended to be used only by adults who have read and understood the instructions and warnings in this manual, and can be considered responsible for their actions.

The product is intended for fastening and removing screws and bolts.

The product is intended for consumer use only.

Do not use the product for any other purpose. Use of the product for operations different from intended could result in a hazardous situation.

**NOTE:** It is recommended to use pilot holes prior to driving screws.

### GENERAL POWER TOOL SAFETY WARNINGS

#### WARNING

**Read all safety warnings, instructions, illustrations and specifications provided with this power tool.** Failure to follow all instructions listed below may result in electric shock, fire and/or serious injury.

**Save all warnings and instructions for future reference.**

The term "power tool" in the warnings refers to your mains-operated (corded) power tool or battery-operated (cordless) power tool.

#### WORK AREA SAFETY

- **Keep work area clean and well lit.** Cluttered or dark areas invite accidents.
- **Do not operate power tools in explosive atmospheres, such as in the presence of flammable liquids, gases or dust.** Power tools create sparks which may ignite the dust or fumes.
- **Keep children and bystanders away while operating a power tool.** Distractions can cause you to lose control.

#### ELECTRICAL SAFETY

- **Power tool plugs must match the outlet. Never modify the plug in any way. Do not use any adapter plugs with earthed (grounded) power tools.** Unmodified plugs and matching outlets will reduce risk of electric shock.
- **Avoid body contact with earthed or grounded surfaces, such as pipes, radiators, ranges and refrigerators.** There is an increased risk of electric shock if your body is earthed or grounded.
- **Do not expose power tools to rain or wet conditions.** Water entering a power tool will increase the risk of electric shock.
- **Do not abuse the cord. Never use the cord for carrying, pulling or unplugging the power tool. Keep cord away from heat, oil, sharp edges or moving parts.** Damaged or entangled cords increase the risk of electric shock.
- **When operating a power tool outdoors, use an**

**extension cord suitable for outdoor use.** Use of a cord suitable for outdoor use reduces the risk of electric shock.

- **If operating a power tool in a damp location is unavoidable, use a residual current device (RCD) protected supply.** Use of an RCD reduces the risk of electric shock.

#### PERSONAL SAFETY

- **Stay alert, watch what you are doing and use common sense when operating a power tool. Do not use a power tool while you are tired or under the influence of drugs, alcohol or medication.** A moment of inattention while operating power tools may result in serious personal injury.
- **Use personal protective equipment. Always wear eye protection.** Protective equipment such as dust mask, non-skid safety shoes, hard hat or hearing protection used for appropriate conditions will reduce personal injuries.
- **Prevent unintentional starting. Ensure the switch is in the off-position before connecting to power source and/or battery pack, picking up or carrying the tool.** Carrying power tools with your finger on the switch or energising power tools that have the switch on invites accidents.
- **Remove any adjusting key or wrench before turning the power tool on.** A wrench or a key left attached to a rotating part of the power tool may result in personal injury.
- **Do not overreach. Keep proper footing and balance at all times.** This enables better control of the power tool in unexpected situations.
- **Dress properly. Do not wear loose clothing or jewellery. Keep your hair and clothing away from moving parts.** Loose clothes, jewellery or long hair can be caught in moving parts.
- **If devices are provided for the connection of dust extraction and collection facilities, ensure these are connected and properly used.** Use of dust collection can reduce dust-related hazards.
- **Do not let familiarity gained from frequent use of tools allow you to become complacent and ignore tool safety principles.** A careless action can cause severe injury within a fraction of a second.

#### POWER TOOL USE AND CARE

- **Do not force the power tool. Use the correct power tool for your application.** The correct power tool will do the job better and safer at the rate for which it was designed.
- **Do not use the power tool if the switch does not turn it on and off.** Any power tool that cannot be controlled with the switch is dangerous and must be repaired.
- **Disconnect the plug from the power source and/or remove the battery pack, if detachable, from the power tool before making any adjustments, changing accessories, or storing power tools.** Such preventive safety measures reduce the risk of starting the power tool accidentally.
- **Store idle power tools out of the reach of children and do not allow persons unfamiliar with the power tool or these instructions to operate the power tool.**

Power tools are dangerous in the hands of untrained users.

- **Maintain power tools and accessories. Check for misalignment or binding of moving parts, breakage of parts and any other condition that may affect the power tool's operation. If damaged, have the power tool repaired before use.** Many accidents are caused by poorly maintained power tools.
- **Keep cutting tools sharp and clean.** Properly maintained cutting tools with sharp cutting edges are less likely to bind and are easier to control.
- **Use the power tool, accessories and tool bits etc. in accordance with these instructions, taking into account the working conditions and the work to be performed.** Use of the power tool for operations different from those intended could result in a hazardous situation.
- **Keep handles and grasping surfaces dry, clean and free from oil and grease.** Slippery handles and grasping surfaces do not allow for safe handling and control of the tool in unexpected situations.

#### BATTERY TOOL USE AND CARE

- **Recharge only with the charger specified by the manufacturer.** A charger that is suitable for one type of battery pack may create a risk of fire when used with another battery pack.
- **Use power tools only with specifically designated battery packs.** Use of any other battery packs may create a risk of injury and fire.
- **When battery pack is not in use, keep it away from other metal objects, like paper clips, coins, keys, nails, screws or other small metal objects, that can make a connection from one terminal to another.** Shorting the battery terminals together may cause burns or a fire.
- **Under abusive conditions, liquid may be ejected from the battery; avoid contact. If contact accidentally occurs, flush with water. If liquid contacts eyes, additionally seek medical help.** Liquid ejected from the battery may cause irritation or burns.
- **Do not use a battery pack or tool that is damaged or modified.** Damaged or modified batteries may exhibit unpredictable behaviour resulting in fire, explosion or risk of injury.
- **Do not expose a battery pack or tool to fire or excessive temperature.** Exposure to fire or temperature above 130°C may cause explosion.
- **Follow all charging instructions and do not charge the battery pack or tool outside the temperature range specified in the instructions.** Charging improperly or at temperatures outside the specified range may damage the battery and increase the risk of fire.

#### SERVICE

- **Have your power tool serviced by a qualified repair person using only identical replacement parts.** This will ensure that the safety of the power tool is maintained.
- **Never service damaged battery packs.** Service of battery packs should only be performed by the

manufacturer or authorized service providers.

#### SCREWDRIVER SAFETY WARNINGS

- **Hold the power tool by insulated gripping surfaces, when performing an operation where the fastener may contact hidden wiring.** Fasteners contacting a "live" wire may make exposed metal parts of the power tool "live" and could give the operator an electric shock.
- Ambient temperature range for tool during operation is between 0°C and 40°C.
- Ambient temperature range for tool storage is between 0°C and 40°C.
- The recommended ambient temperature range for the charging system during charging is between 10°C and 38°C.

#### CHARGER SAFETY WARNINGS

- Before using battery charger, read all instructions and cautionary markings in this manual, on battery charger, battery, and product using battery to prevent misuse of the products and possible injury or damage.
- Do not use charger outdoors or expose to wet or damp conditions. Water entering charger will increase the risk of electric shock.
- Use of an attachment not recommended or sold by the battery charger manufacturer may result in a risk of fire, electric shock, or injury to persons. Following this rule will reduce the risk of electric shock, fire, or serious personal injury.
- Do not abuse cord or charger. Never use the cord to carry the charger. Do not pull the charger cord rather than the plug when disconnecting from receptacle. Damage to the cord or charger could occur and create an electric shock hazard. Replace damaged cords immediately.
- Make sure cord is located so that it will not be stepped on, tripped over, come in contact with sharp edges or moving parts or otherwise subjected to damage or stress. This will reduce the risk of accidental falls, which could cause injury, and damage to the cord, which could result in electric shock.
- Keep cord and charger from heat to prevent damage to housing or internal parts.
- Do not operate charger with a damaged cord or plug, which could cause shorting and electric shock. If damaged, have the charger replaced by an authorised serviceman.
- Do not operate charger if it has received a sharp blow, been dropped, or otherwise damaged in any way. Take it to an authorised serviceman for electrical check to determine if the charger is in good working order.
- Do not disassemble charger. Take it to an authorised serviceman when service or repair is required. Incorrect reassembly may result in a risk of electric shock or fire.
- Unplug charger from outlet before attempting any maintenance or cleaning to reduce the risk of electric shock.
- Disconnect charger from the power supply when not in use. This will reduce the risk of electric shock or damage to the charger if metal items should fall into the opening. It also will help prevent damage to the charger during a power surge.

- Risk of electric shock. Do not touch uninsulated portion of output connector or uninsulated battery terminal.

## BATTERY SAFETY WARNINGS



### Li-ion

- Do not dispose of used battery packs in the household refuse or by burning them. To ensure proper disposal of waste battery packs and protect the environment, hand over old battery packs to your Ryobi distributor.
- Segregate electronic waste properly by removing integrated battery packs from the main unit before disposal. Hand them over to applicable collection points.
- To remove the integrated battery pack: Separate the housing shells from one another by removing the screws. Disconnect the battery pack from the circuit and remove.
- NOTE: When opened, the product is no longer reusable or serviceable and should be disposed of properly.
- Before removing the battery pack from the power tool, switch on the product until the battery pack is fully discharged.
- Ensure that the battery pack to be disposed of cannot come in contact with batteries, other battery packs, or conductive materials by protecting exposed connectors with insulating, non-conductive caps or tape.
- Never charge a damaged battery pack.

## ADDITIONAL BATTERY SAFETY WARNINGS

### ⚠ WARNING

To reduce the risk of fire, personal injury, and product damage due to a short circuit, never immerse your tool in fluids or allow a fluid to flow inside it. Corrosive or conductive fluids, such as seawater, certain industrial chemicals, and bleach or bleach-containing products, etc., can cause a short circuit.

- Ambient temperature range for battery during use is between 0°C and 40°C.
- Ambient temperature range for battery storage is between 0°C and 20°C.

## RESIDUAL RISKS

Even when the product is used as prescribed, it is still impossible to completely eliminate certain residual risk factors. The following hazards may arise and the operator should pay special attention to avoid the following:

- Damage to hearing caused by noise  
Wear suitable hearing protection and limit exposure.
- Injury to the eyes  
Wear protective eye shields or goggles when using the product.

- Injury caused by vibration  
Limit exposure. Follow the instructions in Risk Reduction.
- Electric shock caused by contact with hidden wires  
Hold the product only by insulated surfaces.
- Injury caused by dust  
Dust created by operating the product can cause respiratory injury. Wear appropriate dust control mask with filters suitable for protecting against particles from the material being worked on.

## RISK REDUCTION

It has been reported that vibrations from handheld tools may contribute to a condition called Raynaud's Syndrome in certain individuals. Symptoms may include tingling, numbness, and blanching of the fingers, usually apparent upon exposure to cold. Hereditary factors, exposure to cold and dampness, diet, smoking, and work practices are all thought to contribute to the development of these symptoms. There are measures that can be taken by the operator to possibly reduce the effects of vibration:

- Keep your body warm in cold weather. When operating the unit, wear gloves to keep the hands and wrists warm. It is reported that cold weather is a major factor contributing to Raynaud's Syndrome.
- After each period of operation, exercise to increase blood circulation.
- Take frequent work breaks. Limit the amount of exposure per day.

If you experience any of the symptoms of this condition, immediately discontinue use and see your doctor about these symptoms.

### ⚠ WARNING

Injuries may be caused, or aggravated, by prolonged use of a tool. When using any tool for prolonged periods, ensure you take regular breaks.

## KNOW YOUR PRODUCT

See page 5.

1. Collet
2. Two-speed gear train
3. Pivot locking button
4. Direction of rotation selector
5. Single bit(25 mm)
6. Switch trigger
7. Charger
8. Charger plug
9. Input jack
10. Handle, insulated gripping surface

## MAINTENANCE

### ⚠ WARNING

The product should never be connected to a power supply when assembling parts, making adjustments, cleaning, performing maintenance, or when the product is not in use. Disconnecting the product will prevent accidental starting that could cause serious injury.

- When servicing, use only identical replacement parts. Use of any other parts may create a hazard or cause product damage.
- Avoid using solvents when cleaning plastic parts. Most plastics are susceptible to various types of commercial solvents and may be damaged by their use. Use clean cloths to remove dirt and carbon dust.
- Do not, at any time, let brake fluids, gasoline, petroleum-based products, penetrating oils, etc., come in contact with plastic parts. They contain chemicals that can damage, weaken, or destroy plastic.
- Always wear safety goggles or safety glasses with side shields during power tool operation or when blowing dust. If operation is dusty, also wear a dust mask.
- For greater safety and reliability, all repairs should be performed by an authorised service centre.

### LUBRICATION

All of the bearings in the product are lubricated with a sufficient amount of high grade lubricant for the life span of the product under normal operating conditions. Therefore, no further lubrication is required.

## ENVIRONMENTAL PROTECTION



Recycle raw materials instead of disposing of as waste. The machine, accessories, and packaging should be sorted for environment-friendly recycling.

## SYMBOLS



Safety alert



CE conformity



EurAsian Conformity Mark



Ukrainian mark of conformity



Please read the instructions carefully before starting the machine.



Please read the instructions carefully before starting the machine.



Class II equipment



No-load speed



Thermal fuse 2A



Volts



Direct current



Revolutions or reciprocations per minute



Wear eye protection



Waste electrical products should not be disposed of with household waste. Please recycle where facilities exist. Check with your local authority or retailer for recycling advice.

## SYMBOLS IN THIS MANUAL



Note



Connect to the power supply.



Charging time



Torque, maximum



Torque, minimum

The following signal words and meanings are intended to explain the levels of risk associated with this product:

### ⚠ DANGER

Indicates an imminently hazardous situation, which, if not avoided, will result in death or serious injury.

### ⚠ WARNING

Indicates a potentially hazardous situation, which, if not avoided, could result in death or serious injury.

### ⚠ CAUTION

Indicates a potentially hazardous situation, which, if not avoided, may result in minor or moderate injury.

### CAUTION

(Without Safety Alert Symbol) Indicates a situation that may result in property damage.

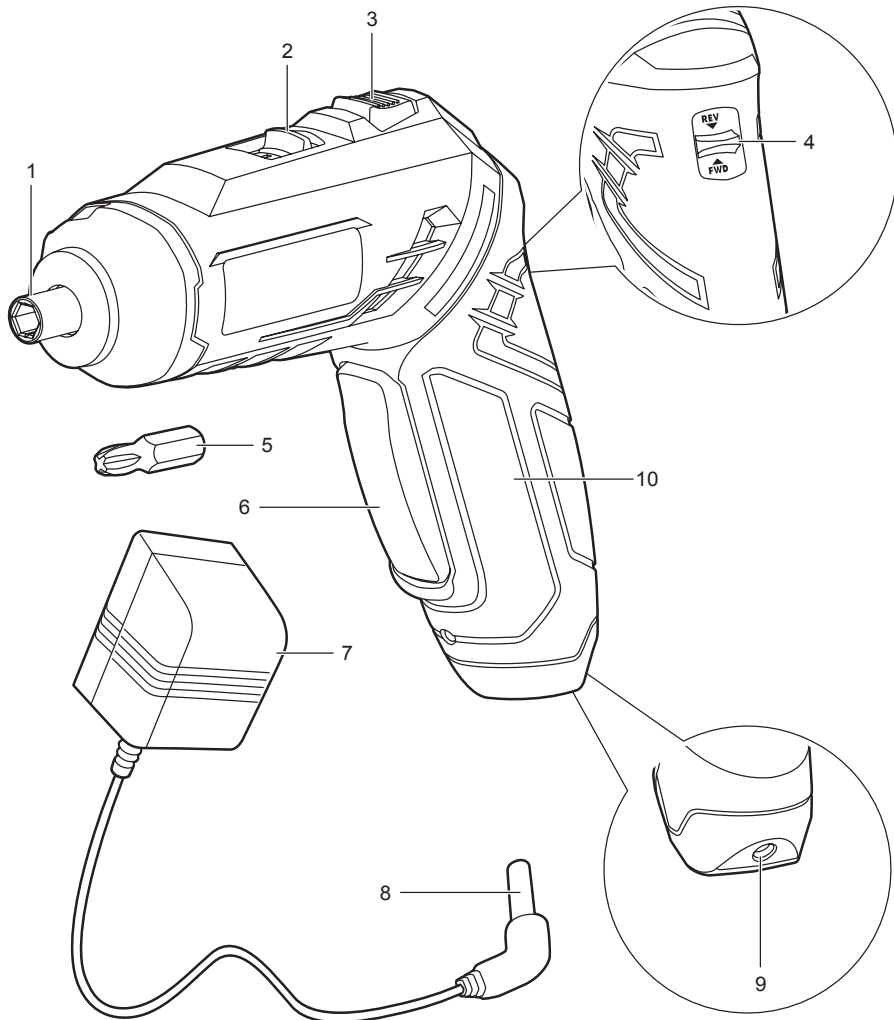

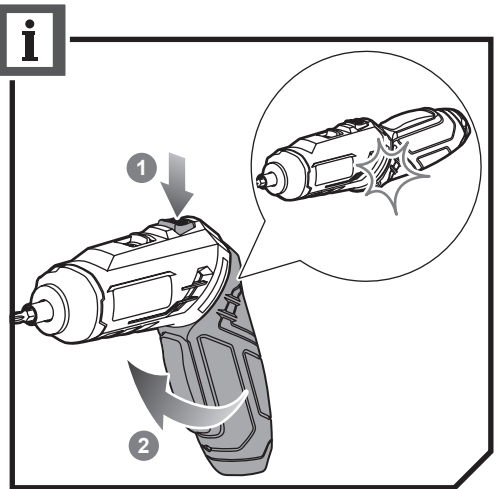
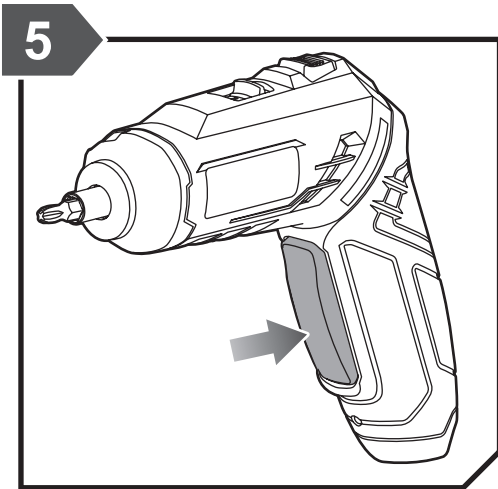
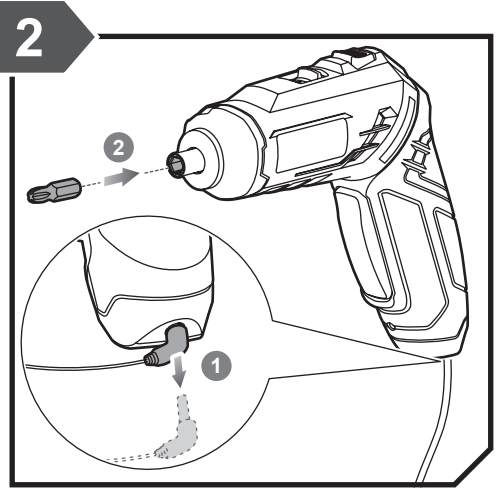
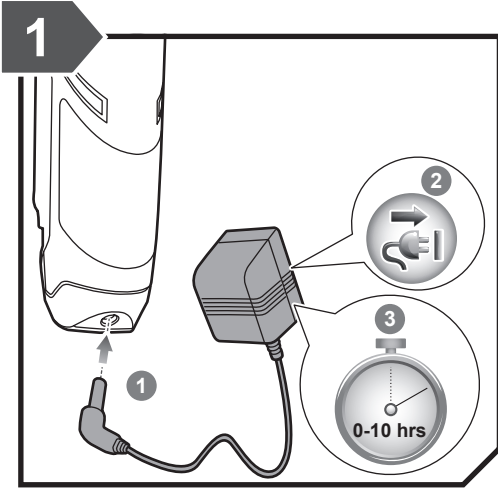



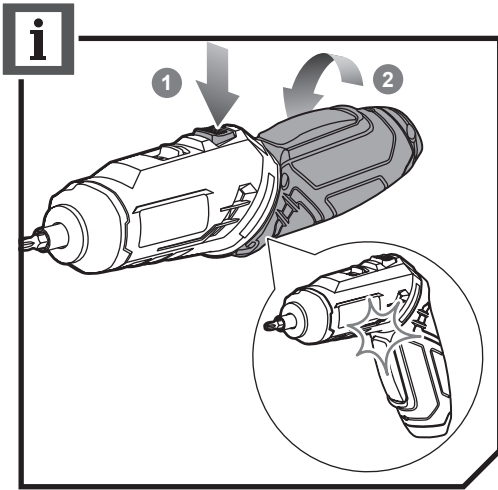
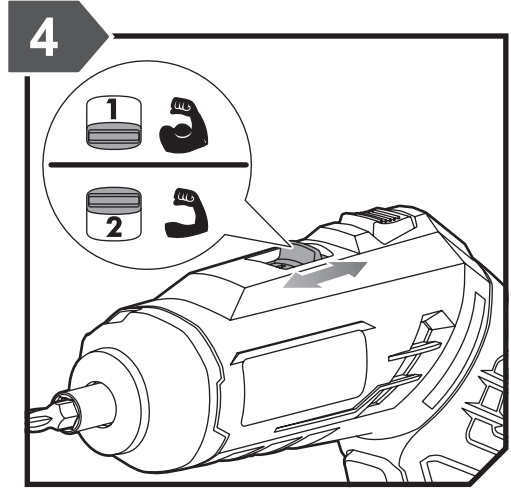
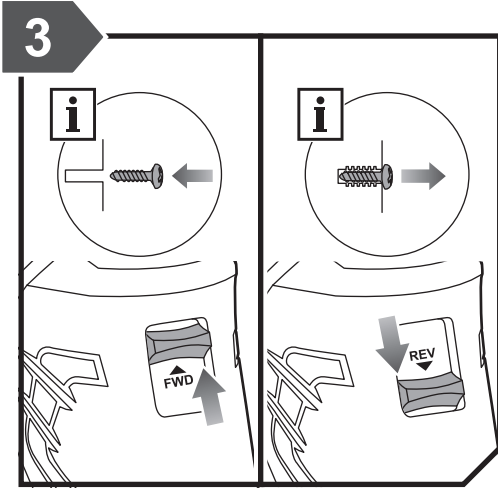

## PRODUCT SPECIFICATIONS

### 4V Screwdriver

|         |                        |
|---------|------------------------|
| Model   | R4SDP                  |
| Voltage | 4 V $\text{---}$       |
| Chuck   | 6.35 mm                |
| Switch  | Two speed / Reversible |

### No load Speed

|            |                       |
|------------|-----------------------|
| - Lo speed | 200 $\text{min}^{-1}$ |
| - Hi speed | 600 $\text{min}^{-1}$ |
| Torque     | 5 Nm                  |

Weight (According to EPTA-Procedure 01/2014) 0.38 kg (1.5Ah)

### Charger Rating

|               |                         |
|---------------|-------------------------|
| Charger model | BC-336 / 720261004      |
| Input         | 230V $\sim$ 50Hz 25mA   |
| Output        | 4.5V $\text{---}$ 160mA |

### Battery

|                  |                  |
|------------------|------------------|
| Voltage          | 4 V $\text{---}$ |
| Battery type     | Lithium Ion      |
| Battery capacity | 1.3Ah            |
| Number of cell   | 1                |

Measured sound values determined according to EN 62841:

|  |                                     |
|--|-------------------------------------|
| A-weighted sound pressure level<br>Uncertainty K | $L_p = 62 \text{ dB(A)}$<br>3 dB(A) |
| A-weighted sound power level<br>Uncertainty K    | $L_w = 73 \text{ dB(A)}$<br>3 dB(A) |

Wear ear protectors.

The vibration total values (triax vector sum) determined according to EN 62841:

|                          |                              |
|--------------------------|------------------------------|
| Vibration emission value |                              |
| Screw driving            | $a_n \leq 2.5 \text{ m/s}^2$ |
| Uncertainty K            | 1.5 $\text{m/s}^2$           |

## VIBRATION LEVEL



### WARNING

The vibration emission level given in this information sheet has been measured in accordance with a standardised test given in EN 62841 and may be used to compare one tool with another. It may be used for a preliminary assessment of exposure. The declared vibration emission level represents the main applications of the tool. However if the tool is used for different applications, with different accessories or poorly maintained, the vibration emission may differ. This may significantly increase the exposure level over the total working period.

An estimation of the level of exposure to vibration should also take into account the times when the tool is switched off or when it is running but not actually doing the job. This may significantly reduce the exposure level over the total working period. Identify additional safety measures to protect the operator from the effects of vibration such as: maintain the tool and the accessories, keep the hands warm and organisation of work patterns.

## RYOBI® WARRANTY APPLICATION CONDITIONS

In addition to any statutory rights resulting from the purchase, this product is covered by a warranty as stated below.

1. The warranty period is 24 months for consumers and commences on the date the product was purchased. This date has to be documented by an invoice or other proof of purchase. The product is designed and dedicated to consumer and private use only. So there is no warranty provided in case of professional or commercial use. This warranty applies only on new products.
2. There is a possibility to extend for a part of the range of power tools (AC/DC) the warranty period over the period described above using the registration on the [www.ryobitools.eu](http://www.ryobitools.eu) website. The eligibility of products for extended warranty is clearly displayed in stores and / or on packaging and is contained within the product documentation. The end user is required to register his/her newly-acquired products online within 30 days from the date of purchase. The end user may register for the extended warranty in his/her country of residence if listed on the online registration form where this option is valid. Furthermore, end users must give their consent to the storage of their personal data that is required to be entered online. They must also accept the terms and conditions. The registration confirmation receipt, which is sent out by e-mail, and the original invoice showing the date of purchase will serve as proof of the extended warranty.
3. The warranty covers all defects of the product during the warranty period due to faults in workmanship or material at the purchase date. The warranty is limited to repair and/or replacement and does not include any other obligations including but not limited to incidental or consequential damages. The warranty is not valid if the product has been misused, used contrary to the instruction manual, or has been incorrectly connected to a power supply. This warranty does not apply to:
  - any damage to the product that is the result of improper or lack of maintenance
  - any product that has been altered or modified
  - any product where original identification (trade mark, serial number) markings have been defaced, altered or removed
  - any damage caused by non-observance of the instruction manual
  - any product not displaying the CE approval mark on the rating plate
  - any product that has been attempted to be repaired by a non-authorized warranty service centre or without prior authorisation by Techtronic Industries
  - any product connected to an improper power supply (amps, voltage, frequency)
  - any damage caused by external influences (water, chemical, physical, shocks) or foreign substances
  - normal wear and tear spare parts
  - inappropriate use, overloading of the tool
  - use of non-approved accessories or parts
  - Power tool accessories provided with the tool or purchased separately. including but not limited to screw driver bits, drill bits, abrasive discs, sand paper and blades, lateral guide etc.
  - Components (parts and accessories) subject to natural wear and tear, including but not limited to Service & Maintenance Kits, carbon brushes, bearings, chuck, SDS drill bit attachment or reception, power cord, auxiliary handle, transport carry case, sanding plate, dust bag, dust exhaust tube, felt washers, impact wrench pins & springs, etc.
4. For servicing, the product must be sent or presented to a RYOBI authorised service station listed for each country in the following list of service station addresses. In some countries your local RYOBI dealer undertakes to send the product to the RYOBI service organisation. When sending a product to a RYOBI service station, the product should be safely packed without any dangerous contents such as petrol, marked with sender's address and accompanied by a short description of the fault.
5. A repair / replacement under this warranty is free of charge. It does not constitute an extension or a new start of the warranty period. Exchanged parts or products become our property. In some countries delivery charges or postage will have to be paid by the sender. Your statutory rights arising from the purchase of the product remain unaffected.
6. This warranty is valid in the European Community, Switzerland, Iceland, Norway, Liechtenstein, Turkey and Russia. Outside these areas, please contact your authorised RYOBI dealer to determine if another warranty applies.

## AUTHORISED SERVICE CENTRES

### ACD PLANT LTD

145 Southbank Road  
Coundon  
Coventry, West Midlands  
CV6 1FG  
Phone: 02476 594348  
Email: danmcgunigle@acdplant.co.uk  
Web: www.acdplant.co.uk

### CBS Power Tools Limited

Unit 4, V P Square  
Storeys Bar Rd, Fengate  
Peterborough, Cambridgeshire  
PE1 5YS  
Phone: 01733 343031  
Email: steve@cbspowertools.co.uk  
Web: www.cbspowertools.com

### C D Powertools

76 Old Road  
Churwell Morley, Leeds  
LS27 7TH  
Phone: 0113 2718494  
Email: info@cdpowertools.co.uk  
Web: www.cdpowertools.co.uk

### C J Sinclair Limited

44 Victoria Road  
St Peters  
Broadstairs, Kent  
CT10 2UG  
Phone: 01843 869400  
Email: repairs@cjsinclairftd.co.uk  
Web: www.cjsinclairftd.co.uk

### Powertech Ind Ltd

Unit 2C, Ellison Road  
Norwood Ind, Killamarsh  
Sheffield, South Yorkshire  
S21 2JG  
Phone: 01142 474080  
Email: stores@powertech-industrial.co.uk  
Web: www.powertech-industrial.co.uk

### RYCKO Technical Services LTD

104 Green Lane  
St Albans, Herts  
AL3 6EX  
Phone: 08458 678790  
Email: info@ryckotechnical.com  
Web: www.ryckotechnical.com

### ToolTech Industrial Equipment

227 E Dunhill Road, Macosquin  
Coleraine, Co Londonderry  
BT514LQ  
Phone: 028 70359493  
Email: john@tooltech.org.uk

For an updated list of authorised service centres, visit <http://uk.ryobitools.eu/header/service-and-support/service-agents>.

## DECLARATION OF CONFORMITY

Techtronic Industries GmbH  
Max-Eyth-Straße 10, 71364 Winnenden, Germany

*Herewith we declare that the product*

4V screwdriver  
Brand: RYOBI  
Model number: R4SDP  
Serial number range: 47507701000001 - 47507701999999

*is in conformity with the following European Directives and harmonised standards*

2006/42/EC, 2014/30/EU, 2011/65/EU,  
EN 62841-1:2015, EN 62841-2-2:2014, EN 55014-1:2017, EN 55014-2:2015  
EN 61000-3-2:2014, EN 61000-3-3:2013

*RoHS documentation is compiled according to EN IEC 63000:2018*



Todd Chipner  
Sr. Director, Regulatory & Safety  
Winnenden, Jun. 14, 2019



Authorised to compile the technical file:  
Alexander Krug, Managing Director  
Techtronic Industries GmbH  
Max-Eyth-Straße 10, 71364 Winnenden, Germany

*RYOBI is a trademark of Ryobi Limited,  
and is used under license.  
© 2019 Techtronic Cordless GP. All rights reserved.*

**Techtronic Industries GmbH**  
Max-Eyth-Straße 10,  
71364 Winnenden, Germany