

RBGL250G



IMPORTANT!

It is essential that you read the instructions in this manual before assembling, operating, and maintaining the product. Subject to technical modification.

Safety, performance, and dependability have been given top priority in the design of your grinder sander.

INTENDED USE

- The grinder sander is intended for grinding and shaping metal. It can be used to sharpen metal hand tools (e.g., chisels, axes and knives) or drill bits, remove burrs or sharp edges.
- The product is also intended for sanding metal, wood, plastics, or similar materials.
- The product is designed for dry grinding and sanding only.
- With the proper accessories, the product can be used for cleaning metal surfaces using a wire brush or for buffing and polishing using a cloth wheel.
- Never use the product for cut-off operations.
- The product should only be used in well ventilated areas.

GENERAL POWER TOOL SAFETY WARNINGS

⚠ WARNING

Read all safety warnings, instructions, illustrations and specifications provided with this power tool. Failure to follow all instructions listed below may result in electric shock, fire and/or serious injury.

Save all warnings and instructions for future reference. The term "power tool" in the warnings refers to your mains-operated (corded) power tool or battery-operated (cordless) power tool.

WORK AREA SAFETY

- **Keep work area clean and well lit.** Cluttered or dark areas invite accidents.
- **Do not operate power tools in explosive atmospheres, such as in the presence of flammable liquids, gases or dust.** Power tools create sparks which may ignite the dust or fumes.
- **Keep children and bystanders away while operating a power tool.** Distractions can cause you to lose control.

ELECTRICAL SAFETY

- **Power tool plugs must match the outlet. Never modify the plug in any way. Do not use any adapter plugs with earthed (grounded) power tools.** Unmodified plugs and matching outlets will reduce risk of electric shock.
- **Avoid body contact with earthed or grounded surfaces, such as pipes, radiators, ranges and refrigerators.** There is an increased risk of electric shock if your body is earthed or grounded.
- **Do not expose power tools to rain or wet conditions.** Water entering a power tool will increase the risk of electric shock.
- **Do not abuse the cord. Never use the cord for carrying, pulling or unplugging the power tool. Keep cord away from heat, oil, sharp edges or moving parts.** Damaged or entangled cords increase the risk of electric shock.
- **When operating a power tool outdoors, use an extension cord suitable for outdoor use.** Use of a cord suitable for outdoor use reduces the risk of electric shock.
- **If operating a power tool in a damp location is unavoidable, use a residual current device (RCD)**

protected supply. Use of an RCD reduces the risk of electric shock.

PERSONAL SAFETY

- **Stay alert, watch what you are doing and use common sense when operating a power tool. Do not use a power tool while you are tired or under the influence of drugs, alcohol or medication.** A moment of inattention while operating power tools may result in serious personal injury.
- **Use personal protective equipment. Always wear eye protection.** Protective equipment such as a dust mask, non-skid safety shoes, hard hat, or hearing protection used for appropriate conditions will reduce personal injuries.
- **Prevent unintentional starting. Ensure the switch is in the off -position before connecting to power source and/or battery pack, picking up or carrying the tool.** Carrying power tools with your finger on the switch or energising power tools that have the switch on invites accidents.
- **Remove any adjusting key or wrench before turning the power tool on.** A wrench or a key left attached to a rotating part of the power tool may result in personal injury.
- **Do not overreach. Keep proper footing and balance at all times.** This enables better control of the power tool in unexpected situations.
- **Dress properly. Do not wear loose clothing or jewellery. Keep your hair and clothing away from moving parts.** Loose clothes, jewellery or long hair can be caught in moving parts.
- **If devices are provided for the connection of dust extraction and collection facilities, ensure these are connected and properly used.** Use of dust collection can reduce dust-related hazards.
- **Do not let familiarity gained from frequent use of tools allow you to become complacent and ignore tool safety principles.** A careless action can cause severe injury within a fraction of a second.

POWER TOOL USE AND CARE

- **Do not force the power tool. Use the correct power tool for your application.** The correct power tool will do the job better and safer at the rate for which it was designed.
- **Do not use the power tool if the switch does not turn it on and off.** Any power tool that cannot be controlled with the switch is dangerous and must be repaired.
- **Disconnect the plug from the power source and/or remove the battery pack, if detachable, from the power tool before making any adjustments, changing accessories, or storing power tools.** Such preventive safety measures reduce the risk of starting the power tool accidentally.
- **Store idle power tools out of the reach of children and do not allow persons unfamiliar with the power tool or these instructions to operate the power tool.** Power tools are dangerous in the hands of untrained users.
- **Maintain power tools and accessories. Check for misalignment or binding of moving parts, breakage of parts and any other condition that may affect the power tool's operation. If damaged, have the power tool repaired before use.** Many accidents are caused by poorly maintained power tools.
- **Keep cutting tools sharp and clean.** Properly maintained cutting tools with sharp cutting edges are less likely to bind and are easier to control.
- **Use the power tool, accessories and tool bits etc. in accordance with these instructions, taking into account the working conditions and the work to be performed.** Use of the power tool for operations different from those

intended could result in a hazardous situation.

- **Keep handles and grasping surfaces dry, clean and free from oil and grease.** Slippery handles and grasping surfaces do not allow for safe handling and control of the tool in unexpected situations.

SERVICE

- **Have your power tool serviced by a qualified repair person using only identical replacement parts.** This will ensure that the safety of the power tool is maintained.

GRINDER SANDER SAFETY WARNINGS

- **Always wear safety goggles and a dust mask.**
- **Wear ear protectors. Exposure to noise can cause hearing loss.**
- **The product is not suitable for wet grinding and sanding.**
- **Do not use a damaged accessory. Before each use, inspect the accessory such as abrasive wheels for chips and cracks. After inspecting and installing an accessory, position yourself and bystanders away from the plane of the rotating accessory and run the power tool at maximum no-load speed for one minute.** Damaged accessories will normally break apart during this test time.
- **The rated speed of the accessory must be at least equal to the maximum speed marked on the power tool.** Accessories running faster than their rated speed can break and fly apart.
- **Never grind on the sides of a grinding wheel.** Grinding on the side can cause the wheel to break and fly apart.
- The plug must be plugged into a matching outlet that is properly installed and grounded in accordance with all local codes and ordinances. If you are not sure, have a certified electrician check the receptacle.
- Mount the grinder sander firmly to the workbench, grinding stand or other rigid frame before operation. An unsecured grinder sander is unstable and may move during operation. This may result in damage or injury.
- Provide adequate general or localized lighting to prevent stroboscopic effect and hazards.
- Always use the product with grinding wheel and sanding belt fitted on both spindles in order to limit the risk of contact with the rotating spindles.
- Always use the guards, work rests, transparent screens and spark arrestors as required for the accessory(ies).
- Always adjust the work rest so that the angle between the work rest and the tangent of the grinding wheel is always greater than 85°.
- Prior to operation, inspect the components and any accessories of the grinder sander to ensure there are no conditions that may affect proper operation. Tighten grinding wheel lock nuts, securing bolts and all clamps and guards.
- Prior to each start up, inspect the grinding wheel for damage. Do not use damaged or misshapen wheels. Replace any damaged grinding wheel according to the instructions.
- Check that the wheel rotates freely prior to each start up. With the grinder sander unplugged and the switch turned to OFF, carefully spin the wheel by hand. The wheel should not contact any components of the bench grinder, and there should be no binding or other conditions that may affect proper operation.
- During each start-up, stand to one side of the grinder sander and switch it ON. Let the grinder sander operate at full speed for one minute so that any undetected flaws or cracks of the wheel will become apparent. Do not contact the wheel with the work piece until the grinder sander has reached full speed.
- Keep hands and body parts clear of grinding wheels. Contacting the rotating wheel may cause injury.
- Always use guards and transparent screen. Keep all guards in place and in working order. Operating the grinder sander without guards or with damaged guards may result in injury.
- Avoid burns. Grinding may cause items and the grinding wheel to become hot. Do not touch the grinding wheel or items that may be hot.
- Do not use the grinder sander to work on small items or items which cannot be held properly. The item may be thrown and result in injury.
- Never grind on the side of the wheel. The wheel will shatter. Grind on the face of the wheel only.
- Never leave a running tool unattended. Turn the power switch to OFF. The grinding wheels continue to rotate after the tool is switched off. Do not leave the tool until it has come to a complete stop.
- Never reach behind or beneath the grinding wheels.
- Use ear protection, such as plugs or muffs, during extended periods of operation.
- Remove the plug before carrying out any adjustment, servicing or maintenance. The power cord must remain unplugged whenever you are maintaining your grinder sander.
- Adjust the work rests and spark arrestors frequently so as to compensate for the wear of the grinding wheel.
- Adjust work rests whenever necessary to keep the distance between the work rests and the grinding wheel and sanding belt as small as possible. This distance should be less than or equal to 2 mm. As the diameter of the grinding wheel decreases with use, maintain the maximum work rest distance by adjusting it.
- Adjust spark arrestors whenever necessary to keep the distance between the spark arrestors and the grinding wheels as small as possible. This distance should be less than or equal to 2 mm. As the diameter of the grinding wheel decreases with use, maintain the maximum spark arrestor distance by adjusting it.
- Replace the worn wheel when the distance of 2 mm between the spark arrestor/work rest and the wheel are no longer able to be maintained.
- If the spark arrestor or work rest becomes worn or damaged, replace it with an identical replacement from the authorised service centre.
- When fitting a new grinding wheel, always check that the stated maximum RPM meets or exceeds that stated on the grinder sander. Ensure the wheel diameter and arbor size meet that stated on the specifications. Also check the new wheel for damage, such as flaws or cracks.
- Do not use sanding belt larger than needed.
- Make sure the sanding belt is installed in the correct direction.
- Do not operate the product without a properly tracked and fitted belt. An incorrectly tracked belt may come off the product and cause personal injury or damage to the product.
- **Change the sanding belt frequently to maintain the product's ability to effectively remove material.**
- Do not use a sanding belt which is damaged, torn, or loose. Use only a sanding belt of the correct size.
- Choose a belt of the correct size and appropriate roughness for the task. Use belts with a lower grit number for removing more material, higher grit number for removing less material and for a finer finish. Replace the belt if it becomes damaged, clogged with debris or is worn.
- Do not force the product. Use the correct product for your

application. The correct product will do the job better and safer at the rate for which it was designed.

- Always hold the workpiece firmly when grinding or sanding.
- To minimise the risk of tipping machine, always support long workpieces.
- Never grind or sand more than one workpiece at a time. Do not stack more than one workpiece on the work rest at a time.
- Do not reach into the product while it is running.
- Avoid awkward operations and hand positions where a sudden slip could cause your hand to move into the grinding wheel or sanding belt.
- Avoid kickback by grinding or sanding in accordance with directional arrows.
- Never stand or have any part of your body in line with the path of the workpiece.
- **Chips and splinters must not be removed while the product is running.**
- The dust produced when using the product may be harmful to health. Do not inhale the dust. Use a dust absorption system and wear a suitable dust protection mask. Remove deposited dust thoroughly, e.g. with a vacuum cleaner.

GRINDING WHEEL SAFETY INSTRUCTIONS

WARNING

To reduce the risk of injury, user must read and comply with instructions, warnings and operator's manual before starting to use this grinding wheel. Failure to heed these warnings can result in wheel breakage and serious personal injury. Save these instructions.

- The use of any wheel other than the one recommended in the machine instruction manual may present a risk of personal injury. Use only grinding wheels which have marked speed equal or greater to that marked on the machine.
- Never use grinding wheel that is too thick to allow outer flange to engage with the flats on the spindle. Larger wheels will come in contact with the wheel guards, while thicker wheels will prevent the bolt from securing the wheel on the spindle. Either of these situations could result in a serious accident and can cause serious personal injury.
- This wheel is for grinding and shaping metal. Do not attempt to do cut-off operation.
- This grinding wheel is only suitable for dry grinding.
- Do not use damaged grinding wheels, do not use wheels that are chipped, cracked or otherwise defective.
- Ensure that the abrasive grinding wheel is correctly fitted and tightened before use.
- Machine should never be connected to power supply when you are installing or removing grinding wheels.
- Store your spare grinding wheel carefully.
 - Keep the wheel inside the original package if possible.
 - Store the wheel in a dry area at room temperature.
 - Wheels may be stored vertically on a shelf.
 - Do not allow the wheels to fall or suffer any impact.

Information available on the grinding wheel label

The information on the wheel label is important. Read and check it carefully to ensure you are selecting the correct type of wheel.

1. Manufacturer, supplier, importer or trade mark.
2. Nominal dimensions of grinding wheel, in particular the diameter of the bore.
3. Abrasive type, grain size, grade or hardness, type of

bond and use of reinforcement.

4. Maximum operation speed in metres per second.
5. Maximum permissible speed of rotation in 1/min .
6. For declaration of conformity, the abrasive products shall be marked with EN 12413.
7. Restriction of use and safety warning symbols.
8. Traceability code, eg. A production/batch number, expiry date or series number.

The wheel may require replacement under any of the following circumstances.

- If the face of the grinding wheel is worn unevenly, becomes grooved, or is no longer smooth and flat.
- If the diameter of the grinding wheel is no longer round.
- If the surface of the wheel becomes loaded and dull with workpiece material.
- If there is any sign of damage.
- If it becomes difficult to work with.
- If the work rest / spark arrestor cannot be adjusted to ≤ 2 mm distance from the wheel surface.
- If ≤ 1 cm of disc protrudes from flange. See tips in page 10.

RESIDUAL RISKS

Even when the product is used as prescribed, it is still impossible to completely eliminate certain residual risk factors. The following hazards may arise in use and the operator should pay special attention to avoid the following:

- Risk of contact with unguarded parts of the rotating wheel and belt.
- Burn hazard from contact with hot wheel or work piece.
- Damage to respiratory system if effective dust mask is not worn.
- Damage to hearing if effective hearing protection is not worn.

KNOW YOUR PRODUCT

See page 7.

1. Transparent screen
2. Spark arrestor
3. Wheel guard
4. Wheel dressing tool
5. Sanding belt lock knob
6. Sanding belt adjustment knob
7. Work lamp
8. Sanding belt
9. Grinding wheel
10. Work rest
11. Work rest lock knob (grinder)
12. Water tray
13. On/off switch
14. Mounting hole x 2
15. Sanding belt guard
16. Sander guard
17. Work rest lock knob (sander)
18. Dust port

MAINTENANCE

- Do not modify the product in any way or use accessories not approved by the manufacturer. Your safety and that of others may be compromised.
- Do not use the product if any switches, guards or other functions does not work as intended. Return to an authorised service centre for professional repair or adjustment.
- Do not make any adjustments whilst the product is running.
- Always make sure the power plug has been removed from the mains power source before making adjustments,

lubricating or when doing any maintenance on the product.

- Before and after each use, check the product for damage or broken parts. Keep the product in top working condition by immediately replacing parts with spares approved by the manufacturer.
- Clean out accumulated dust using a brush or vacuum cleaner. Do not use compressed air.
- To assure safety and reliability, all repairs, including changing brushes, should be performed by an authorised service centre.
- If the power cord is damaged, it must be replaced by an authorised service centre in order to avoid a safety hazard.

⚠ WARNING

For greater safety and reliability, all repairs should be performed by an Authorised RYOBI Service Centre.

TRANSPORTATION AND STORAGE

- When storing the product, disconnect the power cord.
- Clean the product using a brush and vacuum cleaner.
- Always carry and lift the product according to the instruction in this user manual.
- Protect the product from any heavy impact or strong vibrations which may occur during transportation in vehicles.
- Secure the product to prevent it from slipping or falling over.
- Store the product and its accessories in a dry, safe place which is not accessible to children.
- We recommend using the original package for storage to protect the product against dust.

ENVIRONMENTAL PROTECTION



Recycle raw materials instead of disposing of as waste. The machine, accessories and packaging should be sorted for environmental-friendly recycling.

SYMBOLS ON THE PRODUCT



Safety alert



Please read the instructions carefully before starting the machine.



European Conformity Mark



British Conformity Mark



Ukraine Conformity Mark



EurAsian Conformity Mark



Wear ear protection



Wear eye protection



Not for wet grinding or cutting



Do not use chipped, cracked or defective grinding wheel.



Wear safety gloves.



Size and speed of grinding wheel



Size and speed of sanding belt



Wheel rotation direction (shown on wheel label)



Wheel rotation direction (shown on wheel guard)



Belt rotation direction



Visible radiation, instructional safeguard

Do not dispose of waste electrical and electronic equipment as unsorted municipal waste. Waste electrical and electronic equipment must be collected separately. Waste light sources have to be removed from the equipment. Check with your local authority or retailer for recycling advice and collection point. According to local regulations, retailers may have an obligation to take back waste electrical and electronic equipment free of charge. Your contribution to the reuse and recycling of waste electrical and electronic equipment helps to reduce the demand of raw materials. Waste electrical and electronic equipment contain valuable and recyclable materials, which can adversely impact the environment and the human health if not disposed of in an environmentally compatible manner. Delete personal data from waste equipment, if any.



SYMBOLS IN THIS MANUAL



Plug in the product.



Unplug the product.



Waiting time for the product to reach full speed



Parts or accessories sold separately

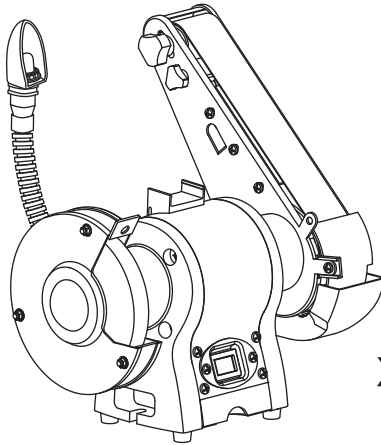

x 1



x 1

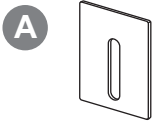

x 1

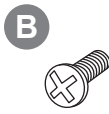

x 1



x 1



x 1

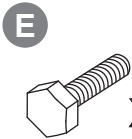

x 1



x 1



x 1



x 1

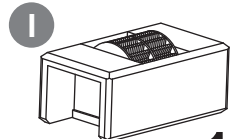

x 1

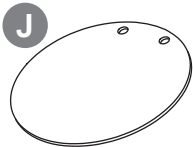

x 1

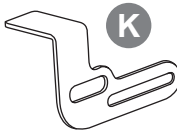

x 1



x 1



x 1



x 1



x 1



x 1



x 1



x 1



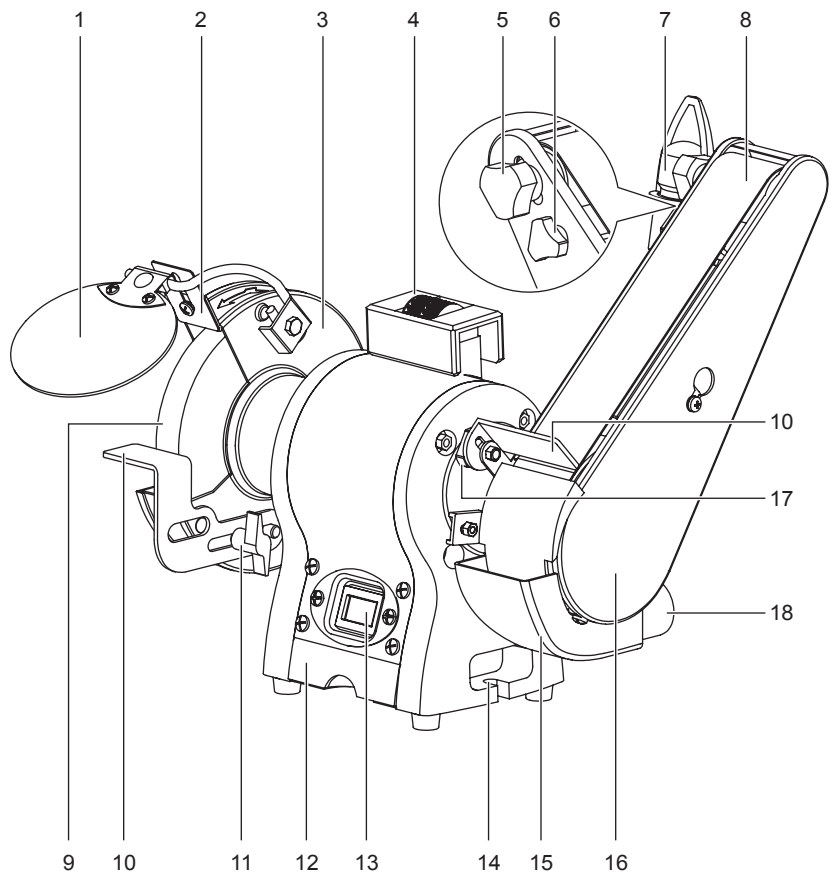

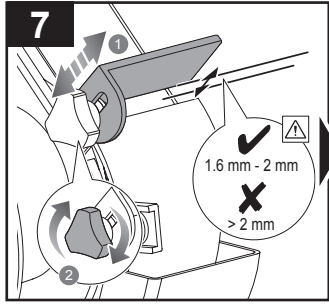
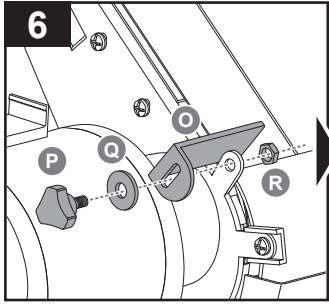
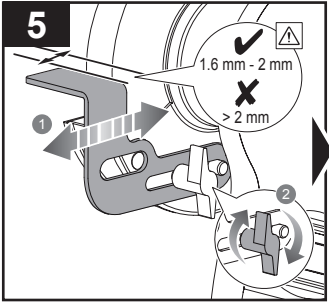
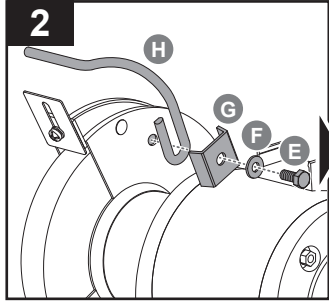
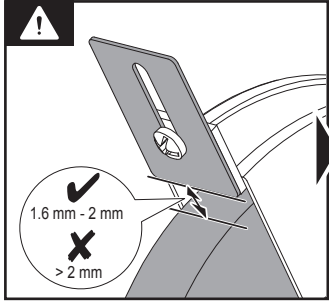
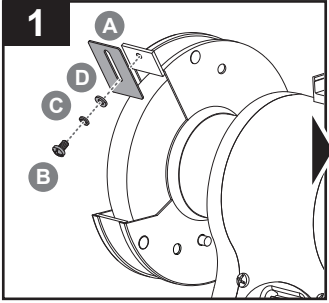

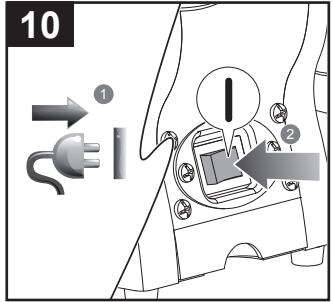
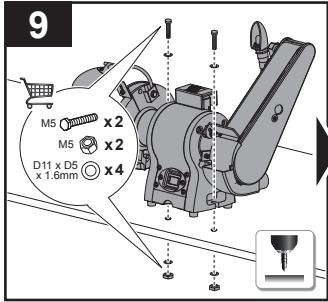
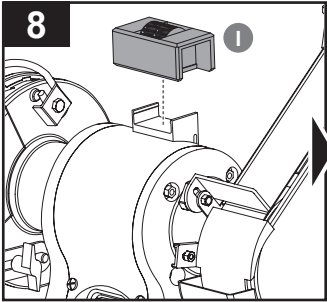
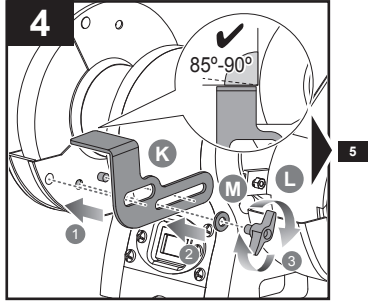
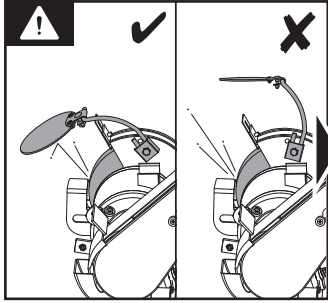
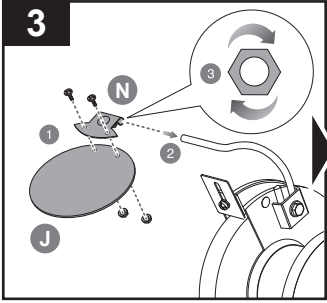

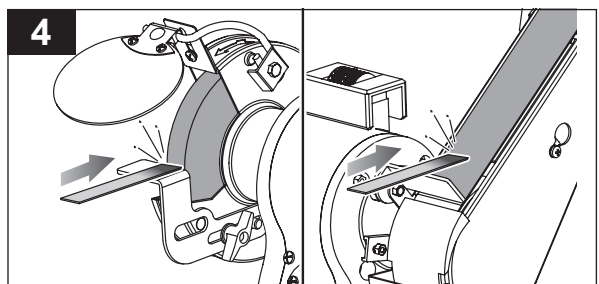
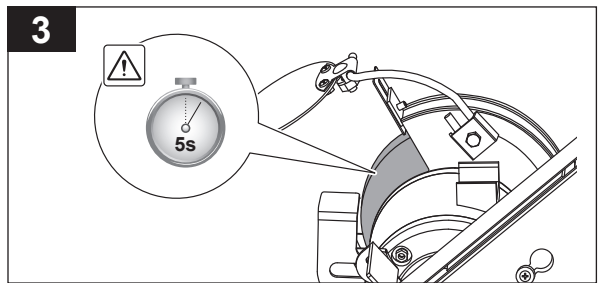
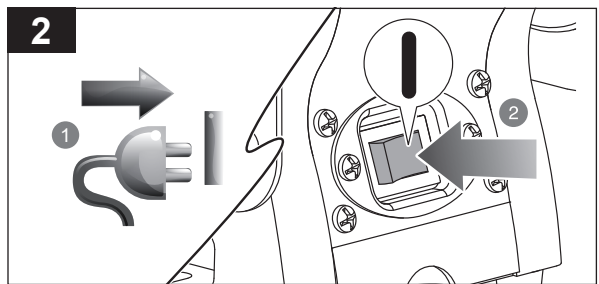
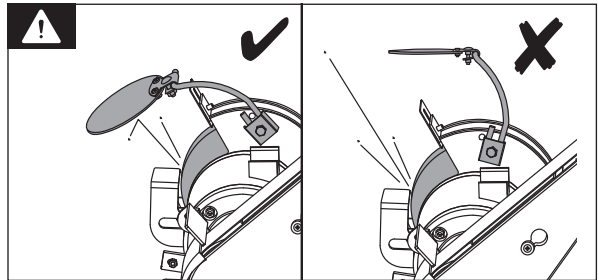
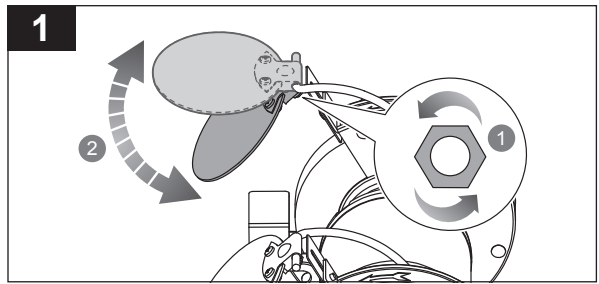
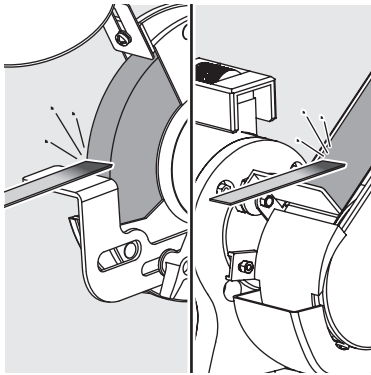

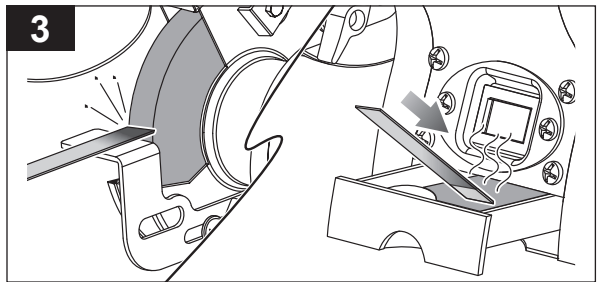
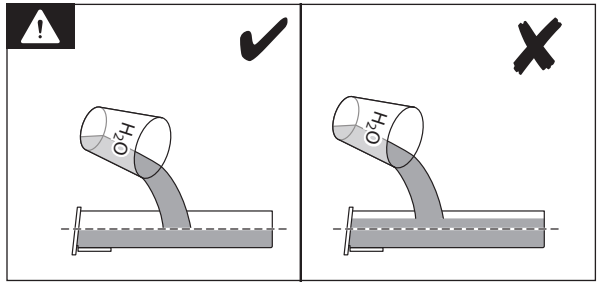
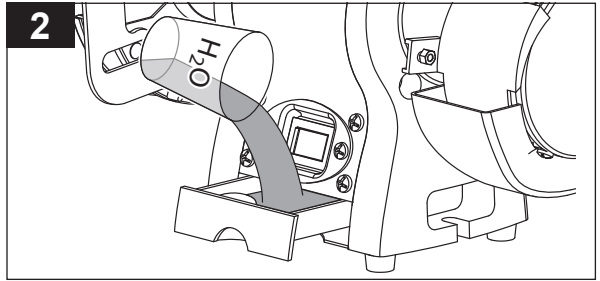
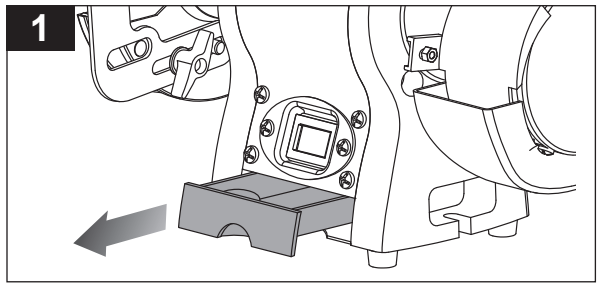
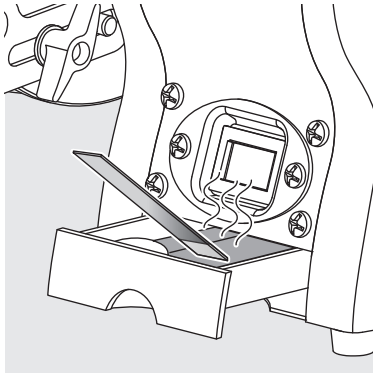

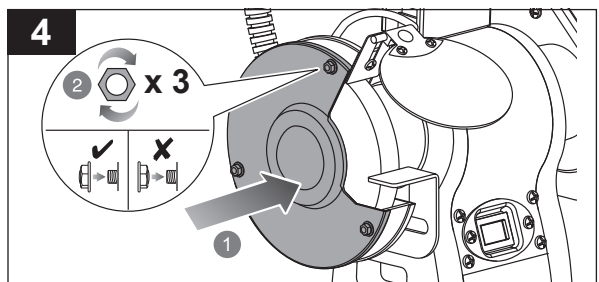
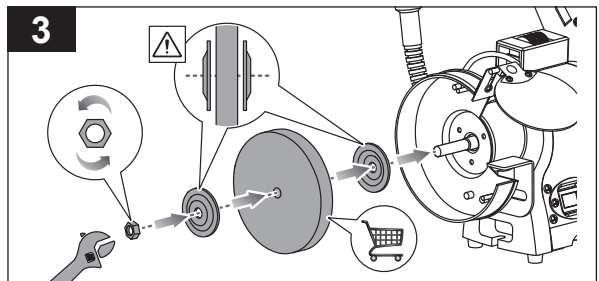
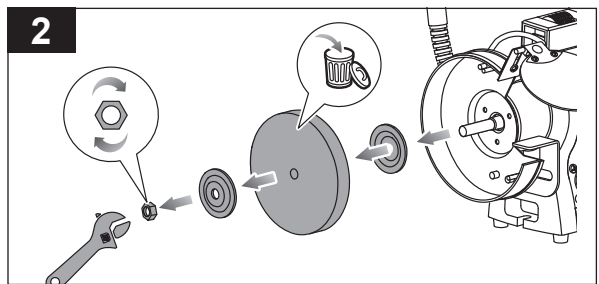
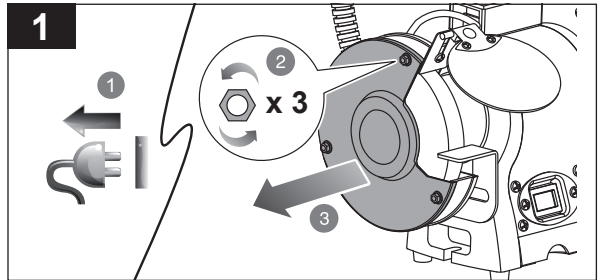
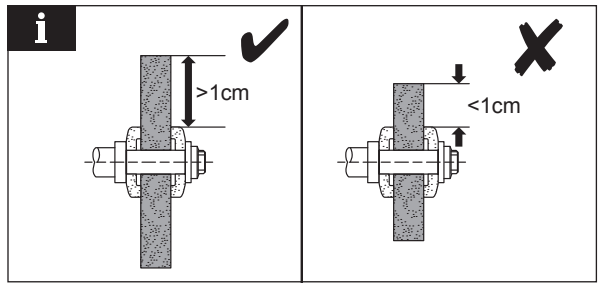
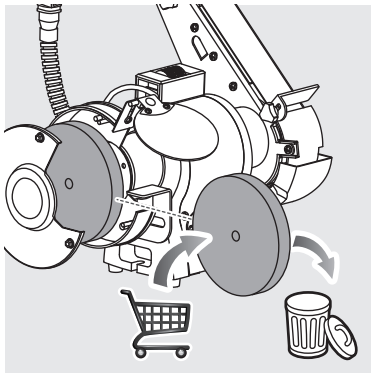

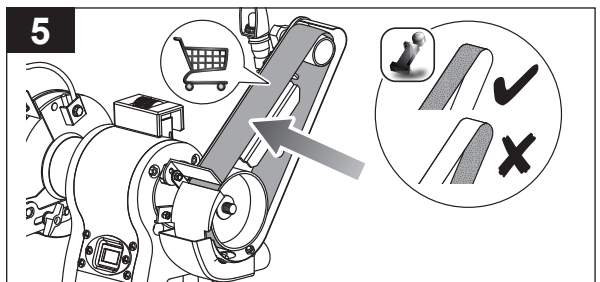
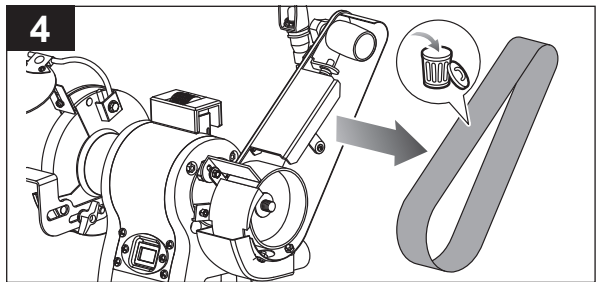
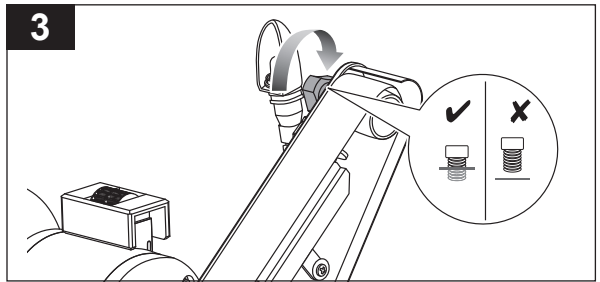
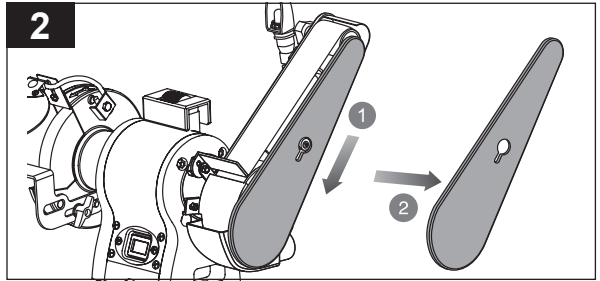
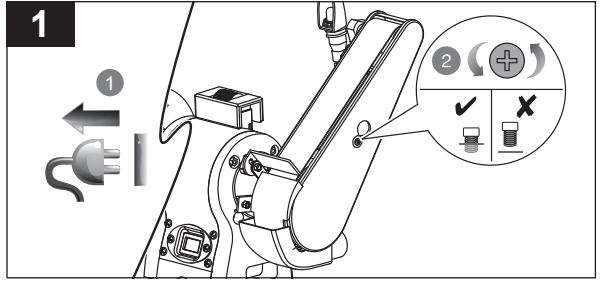

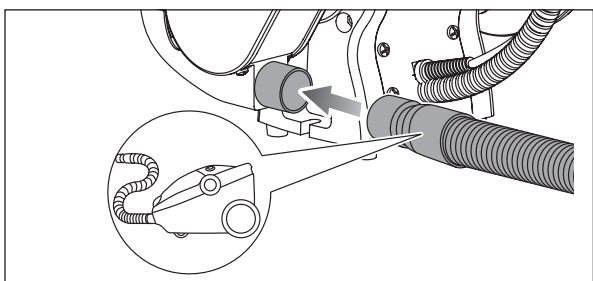
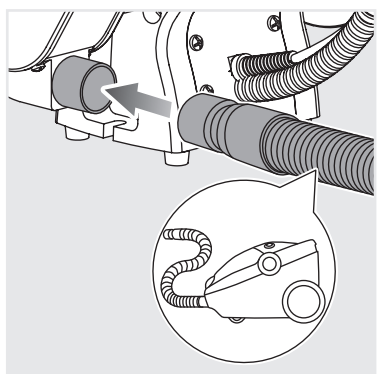
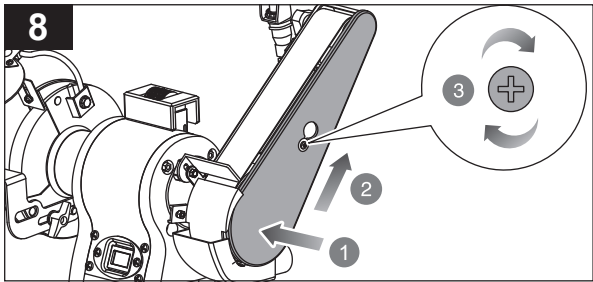
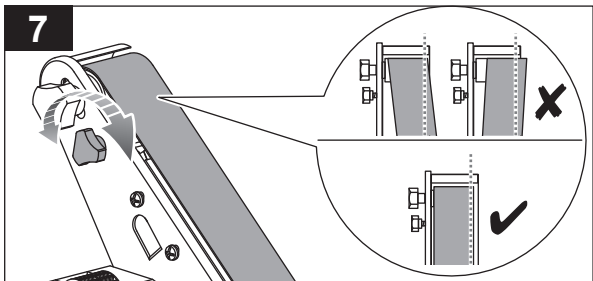
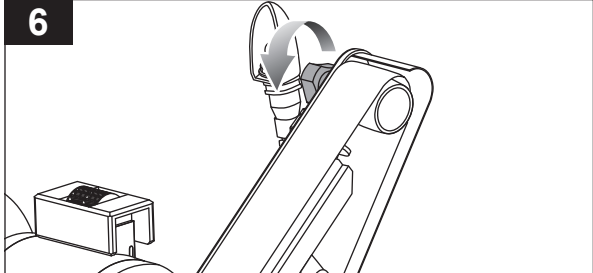

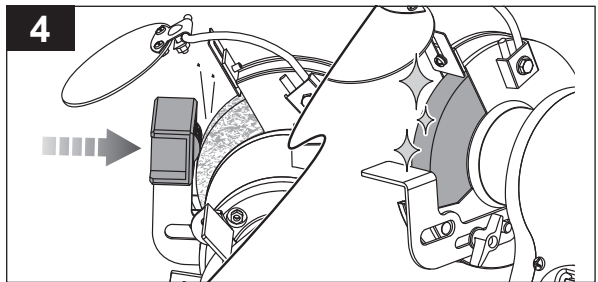
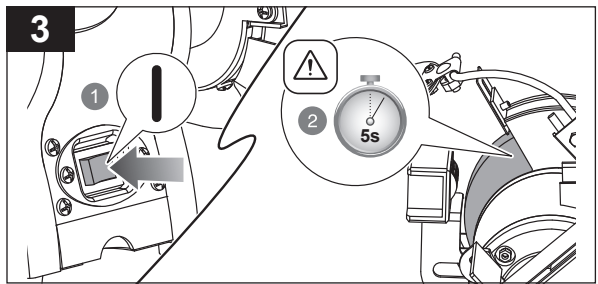
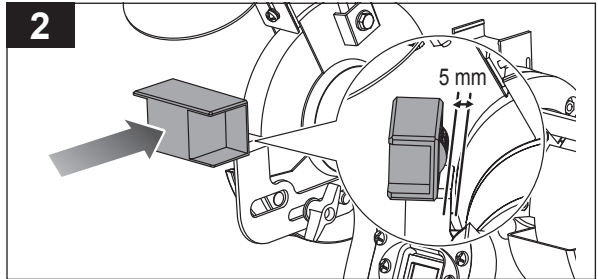
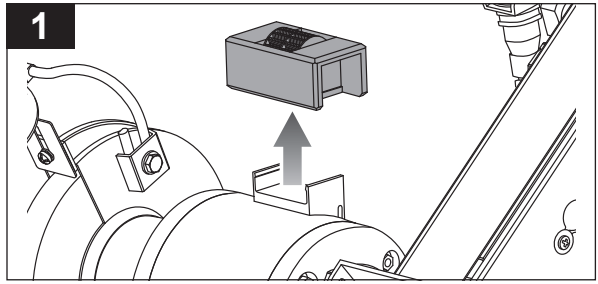
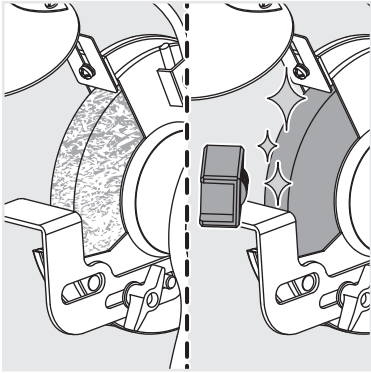

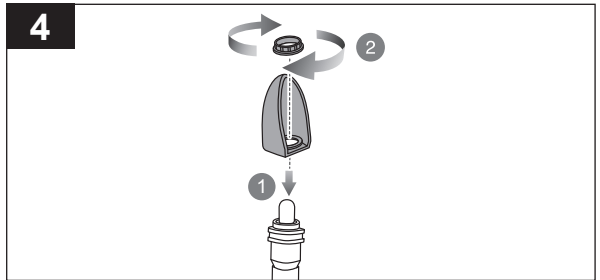
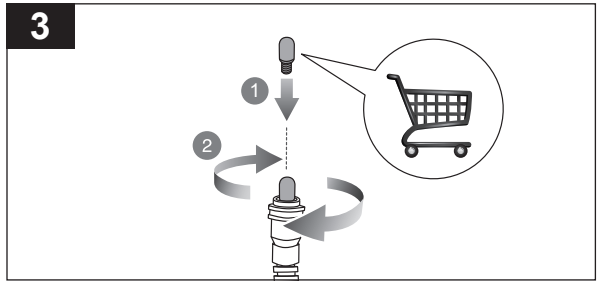
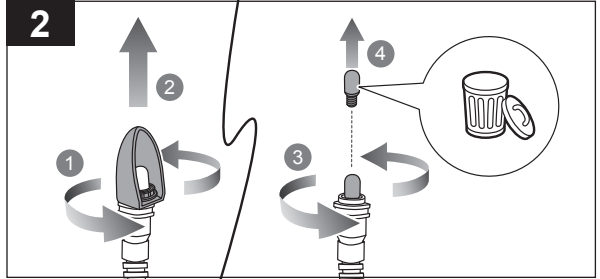
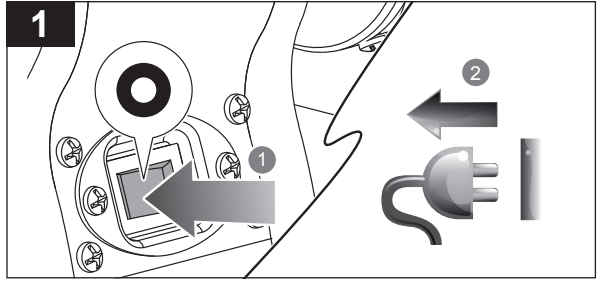
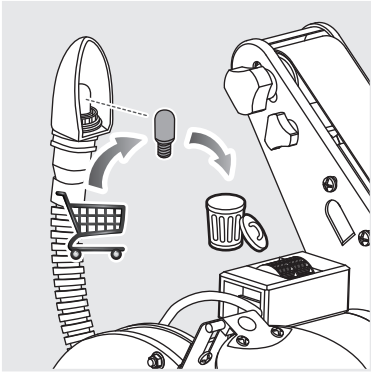

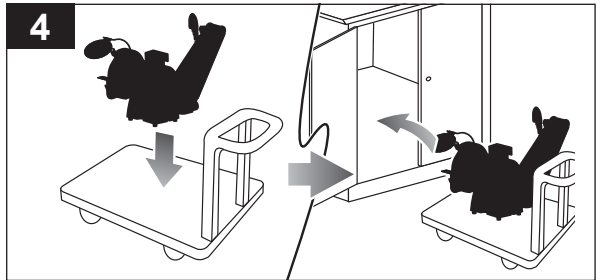
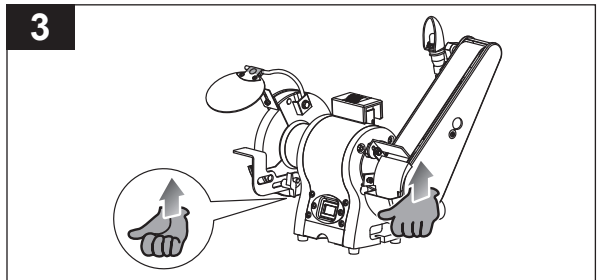
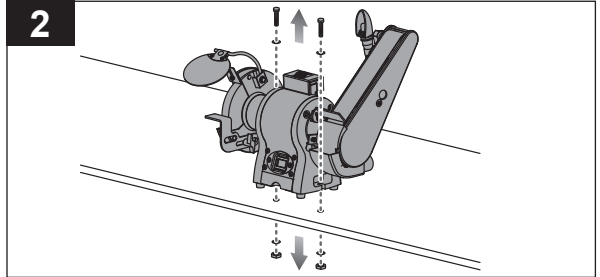
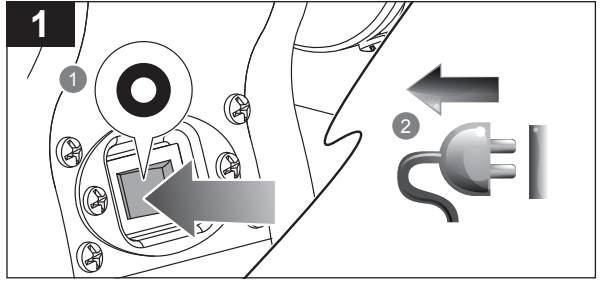

PRODUCT SPECIFICATIONS

Grinder Sander

Model RBGL250G

Motor type Induction

Motor ratings 230V - 240V ~ 50 Hz

Rated power 250 W

Wheel diameter 150 mm

Wheel thickness 20 mm

Bore diameter 12.7 mm

Belt size 50 mm x 686 mm

Belt grits 80#

No-load speed 3000/min

Wheel Grits 36 (Coarse)

Net weight 10.3 kg

Minimum workpiece dimension 2 mm x 2 mm x 30 mm

Measured values determined according to EN 62841

A-weighted sound pressure level $L_{pA} = 83.0 \text{ dB(A)}$

Uncertainty K 3 dB(A)

Measured values determined according to EN 62841

A-weighted sound power level $L_{WA} = 89.5 \text{ dB(A)}$

Uncertainty K 3 dB(A)

⚠ WARNING! The declared noise emission value(s) have been measured in accordance with a standard test method of EN 62841-1 and EN 62841-3-4, and may be used for comparing one tool with another.

The declared noise value(s) may also be used in a preliminary assessment of exposure.

The noise emissions during actual use of the power tool can differ from the declared values depending on the ways in which the tool is used especially what kind of workpiece is processed.

Identify safety measures to protect the operator based on an estimation of exposure in the actual conditions of use (taking account of all parts of the operating cycle such as the times when the tool is switched off and when it is running idle in addition to the trigger time).

Wear hearing protection. Exposure to noise can cause hearing loss.

RYOBI® WARRANTY APPLICATION CONDITIONS

In addition to any statutory rights resulting from the purchase, this product is covered by a warranty as stated below.

1. The warranty period is 24 months for consumers and commences on the date the product was purchased. This date has to be documented by an invoice or other proof of purchase. The product is designed and dedicated to consumer and private use only. So there is no warranty provided in case of professional or commercial use. This warranty applies only on new products.
2. There is a possibility to extend for a part of the range of power tools (AC/DC) the warranty period over the period described above using the registration on the www.ryobitools.eu website. The eligibility of products for extended warranty is clearly displayed in stores and / or on packaging and is contained within the product documentation. The end user is required to register his/her newly-acquired products online within 30 days from the date of purchase. The end user may register for the extended warranty in his/her country of residence if listed on the online registration form where this option is valid. Furthermore, end users must give their consent to the storage of their personal data that is required to be entered online. They must also accept the terms and conditions. The registration confirmation receipt, which is sent out by e-mail, and the original invoice showing the date of purchase will serve as proof of the extended warranty.
3. The warranty covers all defects of the product during the warranty period due to faults in workmanship or material at the purchase date. The warranty is limited to repair and/or replacement and does not include any other obligations including but not limited to incidental or consequential damages. The warranty is not valid if the product has been misused, used contrary to the instruction manual, or has been incorrectly connected to a power supply. This warranty does not apply to:
 - any damage to the product that is the result of improper or lack of maintenance
 - any product that has been altered or modified
 - any product where original identification (trade mark, serial number) markings have been defaced, altered or removed
 - any damage caused by non-observance of the instruction manual
 - any product not displaying the CE approval mark on the rating plate
 - any product that has been attempted to be repaired by a non-authorised warranty service centre or without prior authorisation by Techtronic Industries
 - any product connected to improper power supply (amps, voltage, frequency)
 - any damage caused by external influences (water, chemical, physical, shocks) or foreign substances
 - normal wear and tear spare parts
 - inappropriate use, overloading of the tool
 - use of non-approved accessories or parts
 - Power tool accessories provided with the tool or purchased separately, including but not limited to screw driver bits, drill bits, abrasive discs, sand paper and blades, lateral guide, etc.
 - Components (parts and accessories) subject to natural wear and tear, including but not limited to service & maintenance kits, carbon brushes, bearings, chuck, SDS drill bit attachment or reception, power cord, auxiliary handle, transport carry case, sanding plate, dust bag, dust exhaust tube, felt washers, impact wrench pins & springs, etc.
4. For servicing, the product must be sent or presented to a RYOBI authorised service station listed for each country in the following list of service station addresses. In some countries your local RYOBI dealer undertakes to send the product to the RYOBI service organisation. When sending a product to a RYOBI service station, the product should be safely packed without any dangerous contents such as petrol, marked with sender's address and accompanied by a short description of the fault.
5. A repair / replacement under this warranty is free of charge. It does not constitute an extension or a new start of the warranty period. Exchanged parts or products become our property. In some countries delivery charges or postage will have to be paid by the sender. Your statutory rights arising from the purchase of the product remain unaffected
6. This warranty is valid in the European Community, Switzerland, Iceland, Norway, Liechtenstein, Turkey, Russia, and the United Kingdom. Outside these areas, please contact your authorised RYOBI dealer to determine if another warranty applies.

AUTHORISED SERVICE CENTRES

Any request or issue with the product can be addressed to your local authorised service centres (visit www.ryobitools.eu) or directly to: Techtronic Industries GmbH, Max Eyth Straße 10, 71364 Winnenden, Germany. Please state the serial number and product type printed on the label.

EC DECLARATION OF CONFORMITY

Manufacturer: Techtronic Industries GmbH
Max-Eyth-Straße 10, 71364 Winnenden, Germany

We declare as the manufacturer under our sole responsibility that the product mentioned below

Grinder Sander
Brand: RYOBI
Model number: RBGL250G
Serial number range: 47513402000001 - 47513402999999

fulfills all the relevant provisions of the following European Directives, European Regulations and harmonised standards.

2006/42/EC, 2014/30/EU, 2011/65/EU
EN IEC 55014-1:2021, EN IEC 55014-2:2021,
EN IEC 61000-3-2:2019+A1:2021, EN 61000-3-3:2013+A1:2019,
EN 62841-1:2015, EN 62841-3-4:2016+A11:2017+A12:2020+A1:2020,
EN IEC 63000:2018

Todd Chipner
Vice President, Quality - Asia
Winnenden, Nov. 23, 2022

Authorised to compile the technical file:
Alexander Krug, Managing Director
Techtronic Industries GmbH
Max-Eyth-Straße 10, 71364 Winnenden, Germany

GB-DECLARATION OF CONFORMITY

Manufacturer: Techtronic Industries GmbH
Max-Eyth-Straße 10, 71364 Winnenden, Germany

We declare as the manufacturer under our sole responsibility that the product mentioned below

Grinder Sander
Brand: RYOBI
Model number: RBGL250G
Serial number range: 47513402000001 - 47513402999999

fulfills all the relevant provisions of the following Regulations: S.I. 2008/1597 (as amended), S.I. 2016/1091 (as amended), S.I. 2012/3032 (as amended) and that the following designated standards have been used:

BS EN IEC 55014-1:2021, BS EN IEC 55014-2:2021,
BS EN IEC 61000-3-2:2019+A1:2021, BS EN 61000-3-3:2013+A1:2019,
BS EN 62841-1:2015, BS EN 62841-3-4:2016+A11:2017+A12:2020+A1:2020,
BS EN IEC 63000:2018

Todd Chipner
Vice President, Quality - Asia
Winnenden, Nov. 23, 2022

Authorised to compile the technical file:
Techtronic Industries (UK) Ltd
Parkway
Marlow Bucks SL7 1YL
UK

RYOBI is a trade mark of Ryobi Limited,
and is used under license.

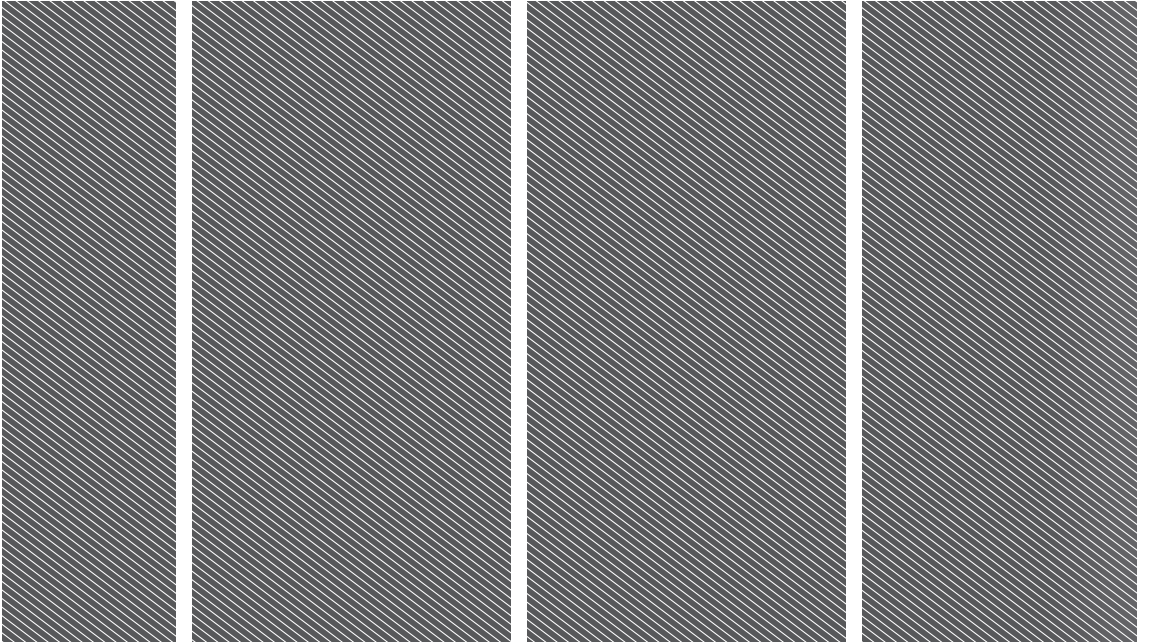

Techtronic Industries GmbH
Max-Eyth-Straße 10,
71364 Winnenden, Germany

Techtronic Industries (UK) Ltd
Parkway
Marlow Bucks SL7 1YL
UK

20230426v8

