

AS AN AID TO REASSEMBLY, TAKE NOTICE OF WIRE ROUTING AND POSITION IN WIRE GUIDES AND TRAPS WHILE DISMANTLING TOOL.

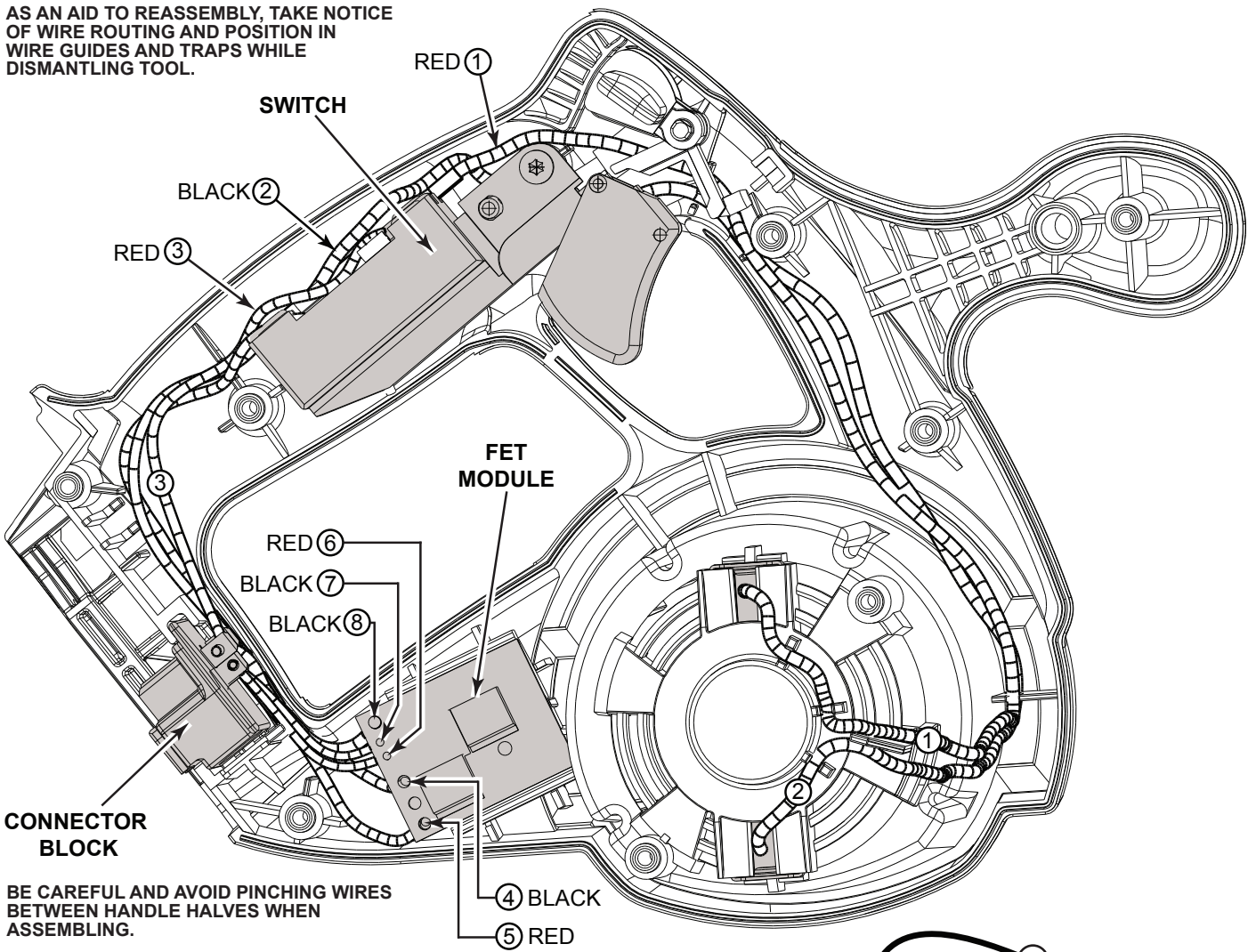

BE CAREFUL AND AVOID PINCHING WIRES BETWEEN HANDLE HALVES WHEN ASSEMBLING.

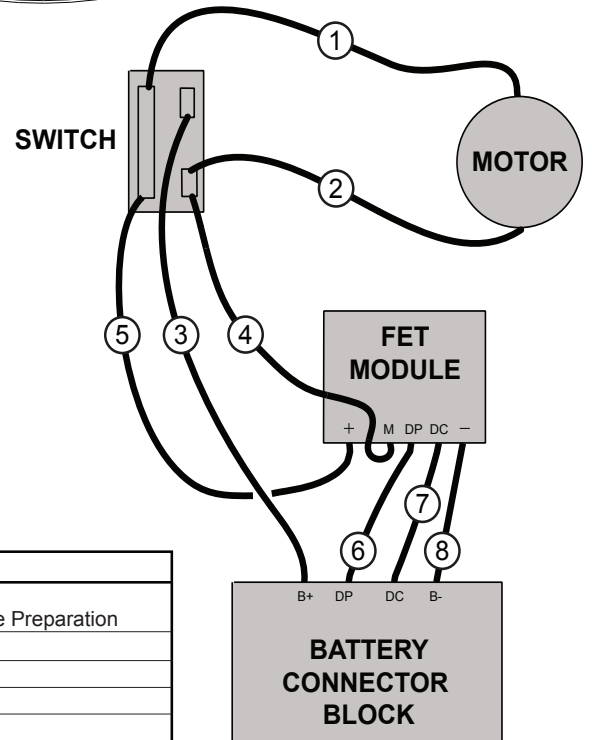

WIRING SPECIFICATIONS

Wire No.	Wire Color	Origin or Gauge	Length	Terminals, Connectors and 1 or 2 End Wire Preparation
1	Red	22-18-1121	-----	Carbon Brush Assembly - Top.
2	Black	22-18-1126	-----	Carbon Brush Assembly - Bottom.
3	Red	23-66-1001	-----	Component of the *Switch Assembly.
4	Black	23-66-1001	-----	Component of the *Switch Assembly.
5	RED	23-66-1001	-----	Component of the *Switch Assembly.
6	Red	23-66-1001	-----	Component of the *Switch Assembly.
7	Black	23-66-1001	-----	Component of the *Switch Assembly.
8	Black	23-66-1001	-----	Component of the *Switch Assembly.

* Switch Assy. No. 23-66-1001 consists of Switch, Connector Block and FET Module & associated wires.